

HONDA
Power
Equipment

170730

OWNER'S MANUAL

Mini-Tiller

FG110

Click here to save this manual to your computer.



See page 27 for instructions on assembling your FG110 Mini-Tiller.

⚠ WARNING: ⚠

The engine exhaust from this product contains chemicals known to the State of California to cause cancer, birth defects, or other reproductive harm.

Keep this owner's manual handy, so you can refer to it any time. This owner's manual is considered a permanent part of the tiller and should remain with the tiller if resold.

The information and specifications included in this publication were in effect at the time of approval for printing. American Honda Motor Co., Inc., reserves the right, however, to discontinue or change specifications or design at any time without notice and without incurring any obligation whatever. No part of this publication may be reproduced without written permission.

INTRODUCTION

Congratulations on your selection of a Honda FG110 Mini-Tiller. We are certain you will be pleased with your purchase of one of the finest tillers on the market.

We want to help you get the best results from your new tiller and to operate it safely. This manual contains the information on how to do that; please read it carefully.

As you read this manual, you will find information preceded by a **NOTICE** symbol. That information is intended to help you avoid damage to your tiller, other property, or the environment.

We suggest you read the *Distributor's Limited Warranty* (page 39) and *Emission Control System Warranty* (page 41) to fully understand coverage and your responsibilities of ownership.

When your tiller needs scheduled maintenance, keep in mind that your Honda servicing dealer is specially trained in servicing Honda tillers. Your Honda servicing dealer is dedicated to your satisfaction, and will be pleased to answer your questions and concerns.

Left and right sides of the unit are determined from the operator's position, standing behind the tiller handlebars, facing the direction of forward travel.

Best Wishes,

Power Equipment Division
American Honda Motor Co., Inc.

A FEW WORDS ABOUT SAFETY

Your safety, and the safety of others, is very important. And using this tiller is an important responsibility.

To help you make informed decisions about safety, we have provided operating procedures and other information on labels in this manual. This information alerts you to potential hazards that could hurt you or others.

Of course, it is not practical or possible to warn you about all the hazards associated with operating or maintaining a tiller. You must use your own good judgment.

You will find important safety information in a variety of forms, including:

- **Safety Labels** – on the tiller.
- **Safety Messages** – preceded by a safety alert symbol  and one of three words: DANGER, WARNING, or CAUTION.

These signal words mean:

 **DANGER**

You WILL be KILLED or SERIOUSLY HURT if you don't follow instructions.

 **WARNING**

You CAN be KILLED or SERIOUSLY HURT if you don't follow instructions.

 **CAUTION**

You CAN BE HURT if you don't follow instructions.

- **Safety Headings**—such as *IMPORTANT SAFETY INFORMATION*.
- **Safety Section**—such as *TILLER SAFETY*.
- **Instructions**—how to use this tiller correctly and safely.

This entire book is filled with important safety information—please read it carefully.

CONTENTS

TILLER SAFETY	4	TECHNICAL & CONSUMER INFORMATION	33
IMPORTANT SAFETY INFORMATION	4	SERIAL NUMBER LOCATIONS	33
ATTACHMENTS AND MODIFICATIONS	5	CARBURETOR MODIFICATIONS FOR HIGH ALTITUDE OPERATION	33
IMPORTANT MESSAGE TO EMPLOYERS	5	OXYGENATED FUELS	34
IMPORTANT MESSAGE TO PARENTS	5	EMISSIONS CONTROL SYSTEM INFORMATION	35
SAFETY LABEL LOCATIONS	6	SPECIFICATIONS	36
CONTROLS & EQUIPMENT	7	TUNEUP	37
COMPONENT & CONTROL LOCATIONS	7	CONSUMER INFORMATION	37
DESCRIPTION OF CONTROLS	8	EMISSION CONTROL SYSTEM WARRANTY ...	41
BEFORE OPERATION	10	INDEX	43
ARE YOU READY TO OPERATE THE TILLER? .	10	QUICK REFERENCE	Inside Back Cover
IS YOUR WORKING AREA READY?	11		
OPERATION	12		
SAFE OPERATING PRECAUTIONS	12		
TILLER OPERATION	14		
SERVICING YOUR TILLER	16		
THE IMPORTANCE OF MAINTENANCE	16		
MAINTENANCE SAFETY	16		
MAINTENANCE SCHEDULE	17		
ENGINE	18		
FUEL SYSTEM	24		
TRANSMISSION LUBRICATION	26		
ASSEMBLY	27		
THE IMPORTANCE OF PROPER ASSEMBLY ...	27		
IMPORTANT SAFETY PRECAUTIONS	27		
UNPACKING	28		
ADDING OIL	28		
BEFORE OPERATION	28		
STORAGE	29		
STORAGE PREPARATION	29		
STORAGE PRECAUTIONS	30		
REMOVAL FROM STORAGE	30		
TRANSPORTING	31		
BEFORE LOADING	31		
LOADING	31		
TAKING CARE OF UNEXPECTED PROBLEMS ..	32		

TILLER SAFETY

IMPORTANT SAFETY INFORMATION

Most accidents can be prevented if you follow all instructions in this manual and on the tiller. The most common hazards, according to accident statistics, are discussed below, along with the best way to protect yourself and others.

Honda Tiller Usage

Honda tillers are designed to give safe and dependable service if operated according to instructions and intended use.

Honda tillers are intended to be used by an experienced, trained operator who is familiar with the use of power equipment. Do not allow a child or an inexperienced, untrained operator to use this tiller. Operating this equipment requires special effort on your part to ensure your safety and the safety of others. Read and understand this owner's manual.

Avoid Rotating Tines

The rotating tines can cause injury. Keep away from the tine shield whenever the engine is running. If you need to adjust the tines or work around the tines for any reason, always stop the engine. Disconnect the spark plug cap if you need to clean or handle the tines.

Clear Tilling Area

The tiller tines can throw rocks and other objects with enough force to cause injury. Before tilling, carefully inspect the area and remove all large debris.

Keep Shields in Place

Guards and shields are designed to protect you from being hit by thrown objects. They also help protect you from hot engine parts and moving components. For your safety and the safety of others, keep all guards and shields in place when operating the tiller.

Refuel with Care

Gasoline is extremely flammable and gasoline vapor can explode. Refuel only outdoors, in a well-ventilated area, with the engine off. Never smoke near gasoline, and keep other flames and sparks away. Always store gasoline in an approved container.

Wear Protective Clothing

Wearing protective clothing will reduce your risk of injury. Long pants and eye protection reduce the risk of injuries from thrown objects. Sturdy shoes with aggressive soles will help protect your feet and give you better traction on slopes or uneven ground. Clothing worn by the operator should be close-fitting. Loose clothing should not be permitted because it may get caught in moving parts. Tie up or restrain long hair.

Turn Engine Off When Not Tilling

If you need to leave the tiller for any reason, even just to inspect the area ahead, always stop the engine.

ATTACHMENTS AND MODIFICATIONS

Do not make any modifications to your tiller. Modifying your tiller, or installing non-Honda attachments, can make your tiller unsafe.

If you need attachments for your tiller, use only genuine Honda attachments. These products have been designed for your tiller. They are covered by the *Accessories, Replacement Parts, and Apparel Warranty* on page 40.

Non-Honda attachments are usually designed for universal applications. Although aftermarket attachments may fit on your tiller, they may not meet factory specifications and could make your tiller unsafe.

IMPORTANT MESSAGE TO EMPLOYERS

As an employer, you have special responsibilities to the people who work for you.

Before you ask anyone to operate this tiller, you need to determine whether the person is old enough, large enough, and strong enough to safely handle and control the tiller.

If you decide the person is, make sure the employee reads and understands all instructions and warnings in this manual, and on the labels before operating the tiller.

Allow adequate time for hands-on training by a qualified instructor, and personally supervise practice sessions until you feel sure the employee is ready to operate the tiller.

Also be sure employees wear proper clothing and have eye protection and any other gear that may be required by local ordinances or your insurance company.

Remember, too, that you are responsible for keeping the tiller properly maintained and in safe operating condition.

Your commitment to safety on the job can help prevent accidents and result in longer and more productive years of service.

IMPORTANT MESSAGE TO PARENTS

Your child's safety is very important to Honda. Read this message if you decide to permit your child to operate this tiller. Tillers are tools, not toys. As with any equipment, bad judgements can result in serious injuries. You can prevent accidents by making good decisions about if, when, and how your child operates this equipment.

The first question you'll need to ask is whether your child is capable of operating this tiller safely. Remember, young people vary widely, and **AGE IS NOT THE ONLY FACTOR**. Physically, a child must be **LARGE ENOUGH AND STRONG ENOUGH** to easily start the tiller and control its direction. The child also needs enough size, strength, and coordination to comfortably reach and operate the controls.

Another, tougher question you need to ask is if your child has enough **MATURITY AND RESPONSIBILITY** to safely operate this tiller. Does the young person think through problems and come to logical solutions? Anyone who takes unnecessary risks and does not obey rules should not operate this tiller.

If you decide that your child can handle the tiller safely, carefully read the owner's manual with him or her. Make sure you both understand all instructions and safety information. Also, be sure your child wears sturdy shoes and other protective clothing when operating or handling the tiller.

SUPERVISION is also very important. Walk with your child during the first few minutes of tilling. Even after he or she has become confident with the tiller, do not let the child use the tiller without good adult supervision. An adult should also be present during refueling and maintenance. In fact, it's up to the adult owner to make sure the tiller is properly maintained and kept in safe operating condition.

By always placing safety first, your child will acquire useful skills and a sense of accomplishment. And you'll both get the best results from your tiller.

TILLER SAFETY

SAFETY LABEL LOCATIONS

The labels shown here contain important safety information. Please read them carefully. These labels are considered permanent parts of your Honda tiller. If a label comes off or becomes hard to read, contact an authorized Honda servicing dealer for a replacement.

⚠ DANGER	
	CONTACT WITH ROTATING TINES WILL CAUSE SERIOUS INJURY. KEEP HANDS, FEET, AND CLOTHING AWAY WHILE ENGINE IS RUNNING.
⚠ WARNING	
TO AVOID SERIOUS INJURY	
<ul style="list-style-type: none">• READ THE OWNER'S MANUAL CAREFULLY BEFORE OPERATION.• KNOW LOCATION AND FUNCTIONS OF ALL CONTROLS.• KEEP ALL SAFETY DEVICES AND SHIELDS IN PLACE AND WORKING.• NEVER ALLOW CHILDREN OR UNINSTRUCTED ADULTS TO OPERATE MACHINE.• SHUT OFF ENGINE BEFORE MANUALLY UNCLOGGING TINES OR MAKING REPAIRS.• KEEP BYSTANDERS AWAY FROM MACHINE.• USE EXTREME CAUTION WHEN REVERSING OR PULLING THE MACHINE TOWARDS YOU.• GASOLINE IS FLAMMABLE AND EXPLOSIVE. STOP ENGINE, AVOID HEAT, SPARKS, AND OPEN FLAME WHEN REFUELING.	

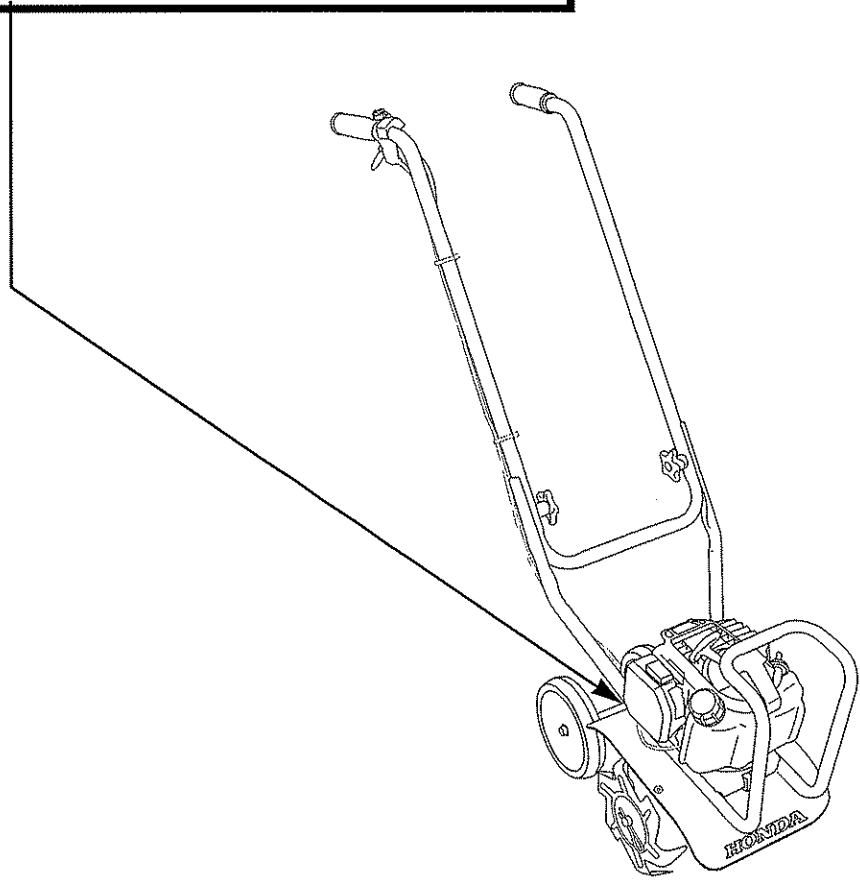

CONTROLS & EQUIPMENT

COMPONENT & CONTROL LOCATIONS

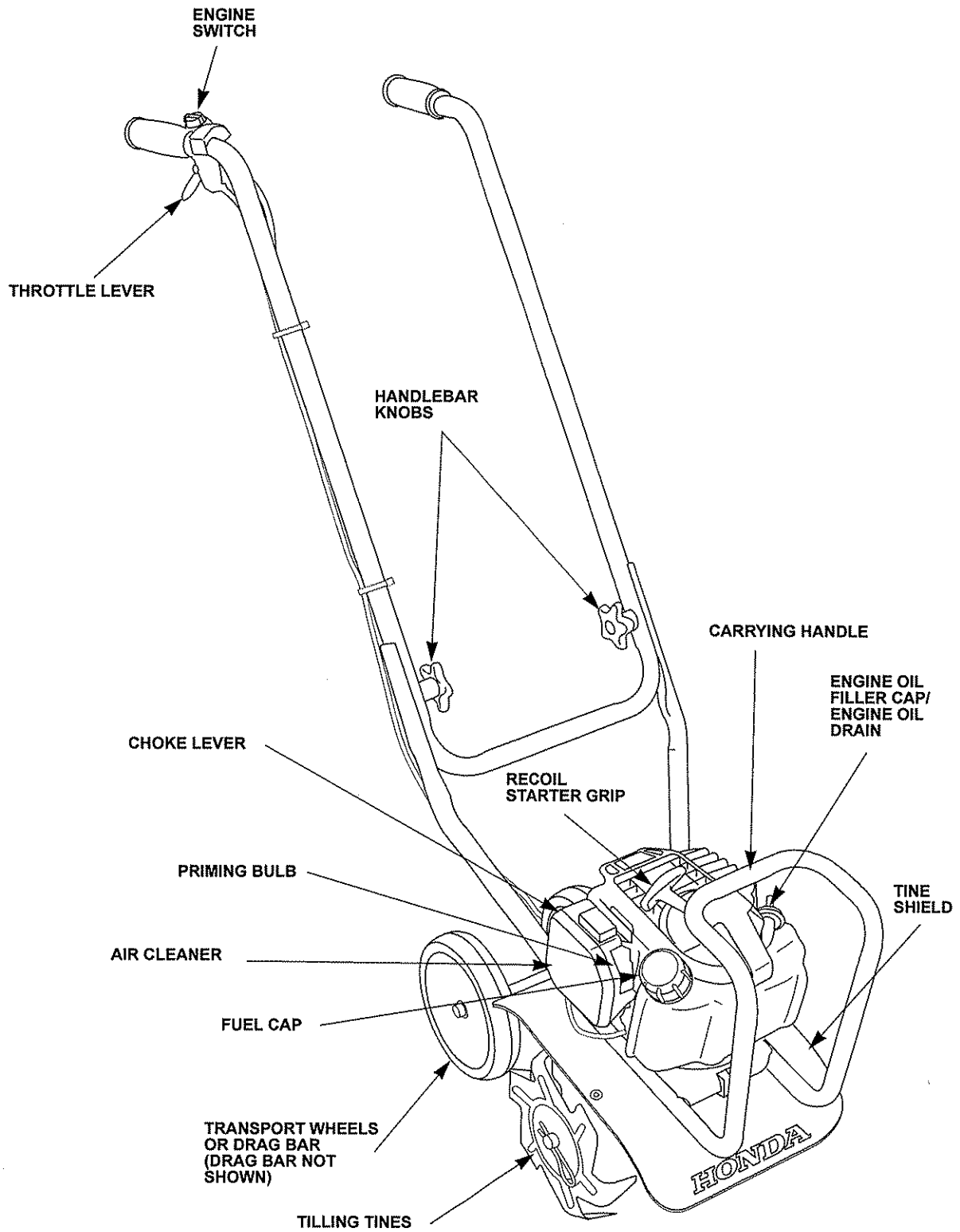

CONTROLS & EQUIPMENT

DESCRIPTION OF CONTROLS

Throttle Lever

The throttle lever controls engine speed and tiller tine rotation.

Pulling the throttle lever towards the grip increases the engine speed which causes the tines to turn. Releasing the throttle lever reduces engine speed and stops the tiller tines from turning.

The tiller will have the greatest tilling force at maximum engine speed. At idle, the tilling tines should stop rotating.

Engine Switch

The engine switch controls the ignition system.

The engine switch must be in the ON position for the engine to start and run. Moving the engine switch to the OFF position stops the engine.

Choke Lever

The choke lever opens and closes the choke valve in the carburetor.

The CLOSED (N) position (choke lever up) enriches the fuel mixture for starting a cold engine. The OPEN position (choke lever down) provides the correct fuel mixture for operation after starting, and for restarting a warm engine.

Priming Bulb

Pressing the priming bulb pumps fuel from the fuel tank to the carburetor. This procedure is necessary for starting a cold engine and after refueling an engine that has run out of fuel.

To ensure that fuel has reached the carburetor, press the priming bulb repeatedly until fuel can be seen in the clear plastic fuel-return tube.

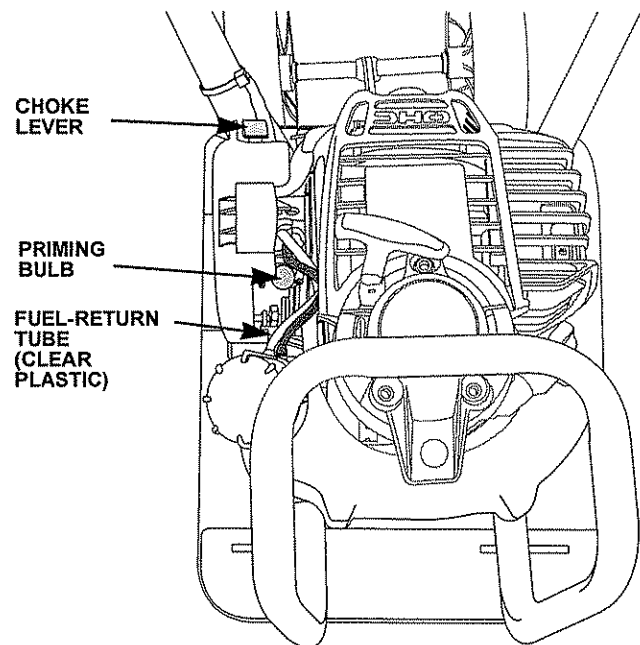
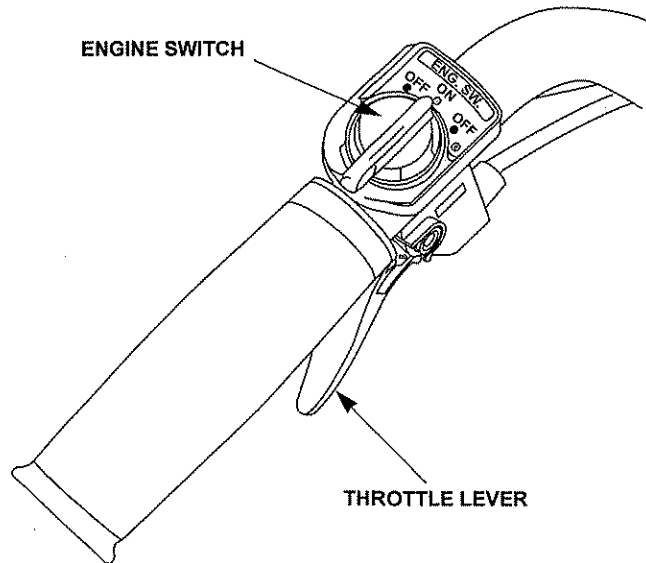

Transport Wheels

The transport wheels are used to move the tiller around. Before tilling, the transport wheels must be removed and the drag bar installed in their place.

Carrying Handle

Hold the carrying handle when starting the engine.

The carrying handle can be used to load/unload the tiller, and to assist in certain engine maintenance procedures.

Recoil Starter Grip

Pulling the starter grip operates the recoil starter to crank the engine for starting.

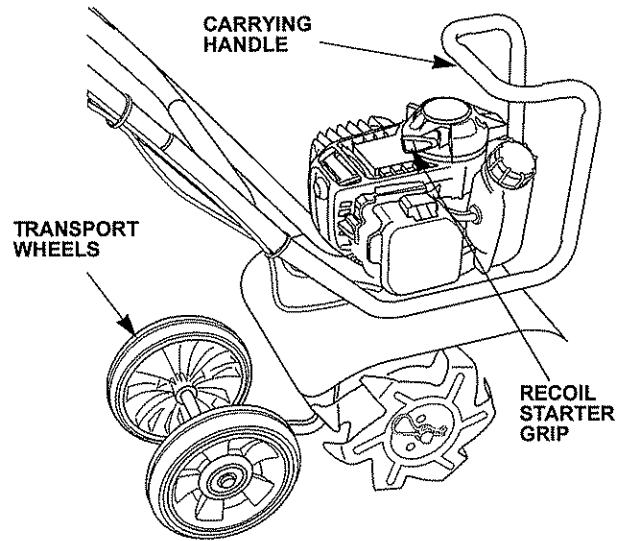

Drag Bar

The drag bar is used to control the forward action of the turning tiller tines. The drag bar can be adjusted to control the tilling depth of the tines.

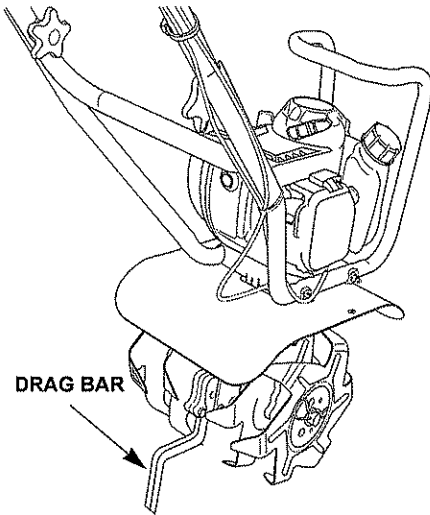

Narrow Cultivating

The two outer tines can be removed to give you a narrower cultivating width. This gives you the ability to get between very closely spaced plants.

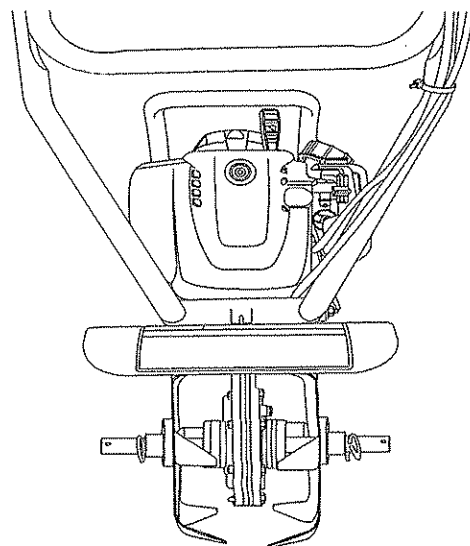

BEFORE OPERATION

ARE YOU READY TO OPERATE THE TILLER?

Your safety is your responsibility. A little time spent in preparation will significantly reduce your risk of injury.

Knowledge

Read and understand this manual. Know what the controls do and how to operate them.

Familiarize yourself with the tiller and its operation before you begin to use it. Know what to do in case of emergencies.

Physical and Mental Readiness

You must be alert and in good physical condition to operate the tiller. Do not operate the tiller if you are tired, ill, or under the influence of alcohol, medication, or any substance that might impair your vision, dexterity, or judgment.

If you have any physical problem that may be aggravated by strenuous work, consult your physician before operating the tiller.

Protective Clothing

Wearing protective clothing will reduce your risk of injury. Do not wear loose clothing, jewelry, short pants, sandals, or go barefoot. Secure hair so it is above shoulder level.

Hand and Body Protection

Wear gloves, a long-sleeved shirt, and long pants made of heavy material. Clothing should fit closely but allow freedom of movement, and should have no strings, straps, etc. that could catch on brush or the tiller. Keep clothing fastened.

Foot Protection

Wear sturdy work boots with good toe protection and nonslip soles.

IS YOUR WORKING AREA READY?

Objects thrown by the tiller can cause serious injury. Before operating the tiller, carefully inspect the area, and remove all objects that could be thrown by, or entangled in, the tilling attachment, such as rocks, broken glass, nails, wire, or string.

Never operate the tiller without good visibility or light.

Clear the area of children, bystanders, and pets. Keep all children, bystanders, and pets at least 50 feet (15 meters) away from where the tiller is being operated.

If anyone approaches you while you are operating the tiller, release the throttle lever and stop the engine.

IS YOUR TILLER READY TO GO?

For your safety, and to maximize the service life of your equipment, it is very important to take a few moments before you operate the tiller to check its condition. Be sure to take care of any problem you find, or have your servicing dealer correct it, before you operate the tiller.

⚠ WARNING

Improperly maintaining this tiller, or failing to correct a problem before operation, could cause a malfunction in which you could be seriously injured.

Always perform a pre-operation inspection before each operation, and correct any problem.

Safety Inspection

- Look around the engine for signs of oil or gasoline leaks. Wipe up any spills before starting the engine.
- Replace any damaged parts.
- Check that all fasteners are in place and secure. Tighten as necessary.

Tiller Tine Inspection

- Look for signs of damage to the tilling tines (or any accessory installed). Replace any tiller tines and parts that are worn out, bent, cracked, chipped, or damaged in any way.
- Make sure the tiller accessory is properly installed and securely fastened (see attachment installation instructions).
- Check that the debris shield is securely installed and in good condition.

Maintenance Inspection

- Check the oil level (see page 18). Running the engine with a low oil level can cause engine damage.
- Check the air filter (see page 19). A dirty air filter will restrict air flow to the carburetor, reducing engine and tiller performance.
- Check throttle operation (see page 23). The throttle must operate smoothly for good throttle control.
- Check the fuel level (see page 24). Starting with a full tank will help to eliminate or reduce operating interruptions for refueling.

OPERATION

SAFE OPERATING PRECAUTIONS

Before operating the tiller for the first time, please review the *IMPORTANT SAFETY INFORMATION* on page 4 and *BEFORE OPERATION* chapter starting on page 10.

Even if you have operated other tillers, take time to become familiar with the operation of this tiller's controls and handling.

For your safety, avoid starting or operating the engine in an enclosed area, such as a garage. Your engine's exhaust contains poisonous carbon monoxide gas which can collect rapidly in an enclosed area and cause illness or death.

If the tiller starts to shake or vibrate, stop the engine immediately. After the tiller tines have completely stopped, inspect them to determine the cause of the vibration. Sudden vibration is a sign of a hazardous problem, such as a loose or damaged tilling tines (or tiller attachment), hidden objects in the soil, or the ground that is too hard to till. Do not operate the tiller until the problem is corrected.

Prolonged exposure to vibration may cause vibration syndrome (Raynaud's disease). Symptoms include loss of skin color in the hands and numbness or a painful tingling sensation in the fingers, hands, and arms. Regular users of any power equipment may feel the numbness or pain spontaneously, at any time, not just after using the equipment. If any of these symptoms occur, see a physician immediately.

Moving the Tiller

Do not move the tiller with the engine running.

The tiller has transport wheels to allow easy maneuvering to and from the work area. Install the transport wheels by inserting the wheel bar up through the transmission housing.

Before tilling, remove the transport wheels and install the drag bar.

Drag Bar Installation

1. Make sure the engine is OFF before installing the drag bar.
2. Remove the lock pin and the 6 x 25 mm clevis pin.
3. Remove the wheel assembly.
4. Install the drag bar with the pointed edge of the drag bar towards the tiller tines using the 6 x 25 mm clevis pin and lock pin.
5. When your tilling job is completed, reinstall the transport wheels in the reverse order of removal.

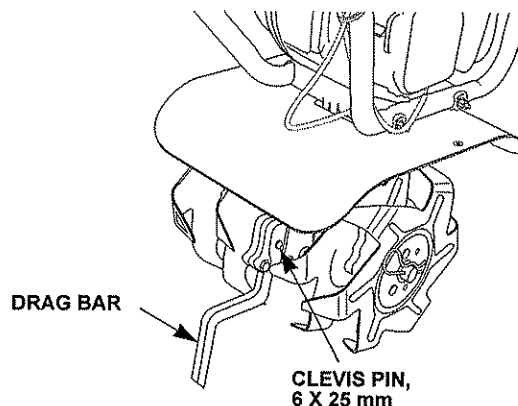
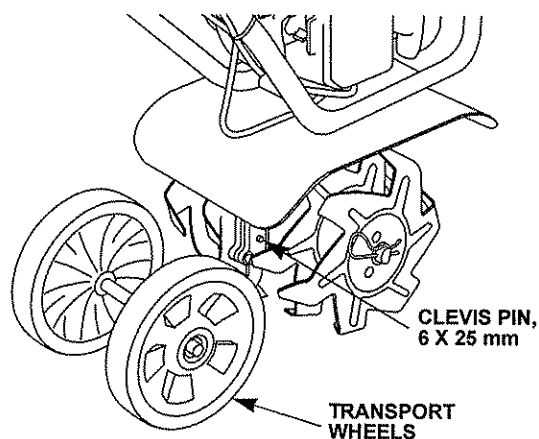

Starting The Engine

1. Move the engine switch to the ON position.
2. To start a cold engine, move the choke lever up to the CLOSED (N) position.

To restart a warm engine, leave the choke lever down in the OPEN position.

3. To start a cold engine, or after refueling an engine that has run out of fuel, press the priming bulb repeatedly until fuel can be seen in the clear plastic fuel-return tube.

To restart a warm engine, it is not necessary to press the priming bulb.

4. Place your left hand on the carrying handle and hold it firmly. Make sure your feet are away from the tiller tines. With your right hand, pull the starter grip lightly until you feel resistance, then pull briskly. Return the starter grip gently.
5. If the choke lever was moved to the CLOSED (N) position, gradually move it to the OPEN position as the engine warms up.

Allow the engine to warm up for a few moments after starting the engine cold.

The tiller tines should not rotate with the engine idling. If there is rotation at idle, adjust the idle speed correctly before using the tiller (see page 23).

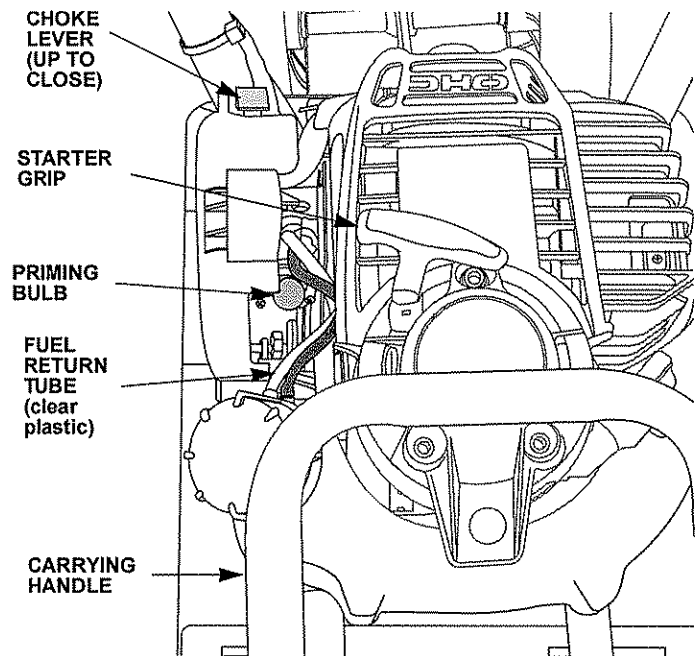
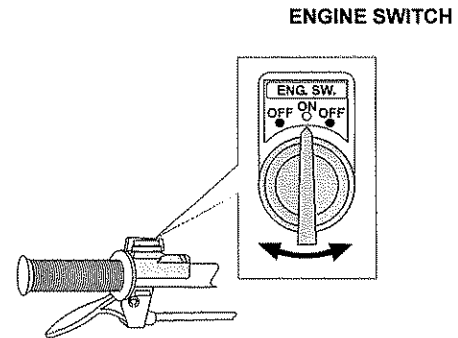

Stopping the Engine

1. Release the throttle lever.
2. Move the engine switch to the OFF position.

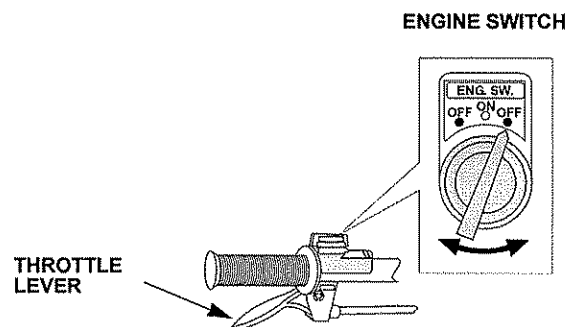

OPERATION

TILLER OPERATION

1. Install the drag bar (see page 12). Honda recommends using the drag bar when tilling. The tiller can be difficult to control without the drag bar installed.
2. Set the tilling depth by moving the drag bar up or down.
The ideal height of the drag bar will depend on the type of soil being tilled, and soil conditions at the time of tilling. In general, however, the drag bar should be adjusted so that the tiller is tilted slightly backward.
3. Start the engine (see page 13).
4. Tilt the tiller back until the tines are off the ground. Squeeze the throttle lever to full speed position (lever tight against the grip).
5. Lower the front of the tiller until the tines begin to dig into the ground.
6. Lower the handle slightly so the front of the tiller is raised about $6 \sim 8^\circ$. To get the maximum advantage from the tiller, hold the tiller at this angle while you are tilling the ground.

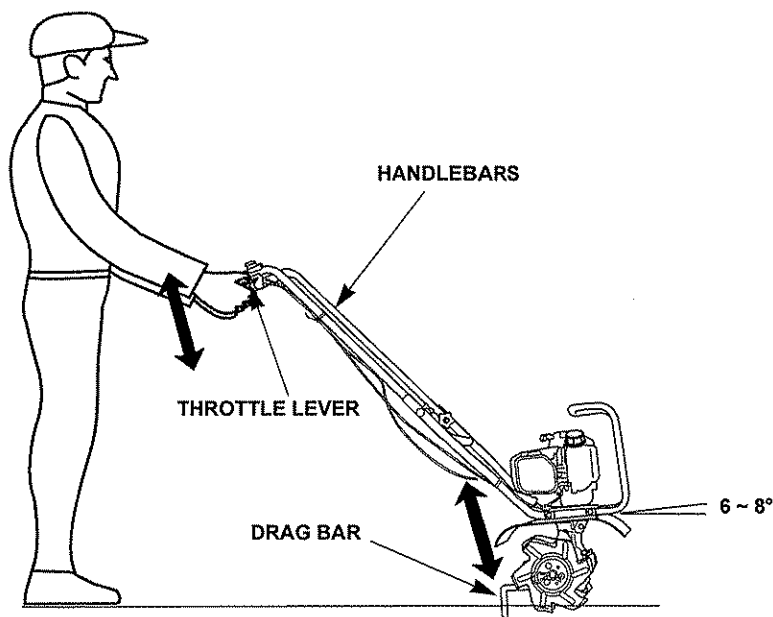

Operating Tips

- If the tiller tends to move forward rapidly, push down on the handlebars to allow the drag bar to penetrate the soil and slow the forward motion of the tiller. Continue to press down until the tiller tines have dug to a desired depth that allows easy tiller handling.
- If the tines dig in but the tiller will not move forward, ease up on the handlebars and move the handlebars from side-to-side. If the tiller still digs in, but will not move forward, raise the drag bar up one hole.
- When turning, push down on the handlebars to bring the tiller's weight to the rear; this will make turning easier.

Narrow Cultivating

The two outer tines can be removed to give you a narrower cultivating width. This width is approximately 5 inches. This gives you the ability to get between very closely spaced plants.

To remove the two outer tines, pull the lock pins out of the holes in the end of the tine shaft. Slide the outside tine set off the tine shaft. Secure the inner set of tines onto the tine shaft by placing the lock pins in the inside set of lock pin holes.

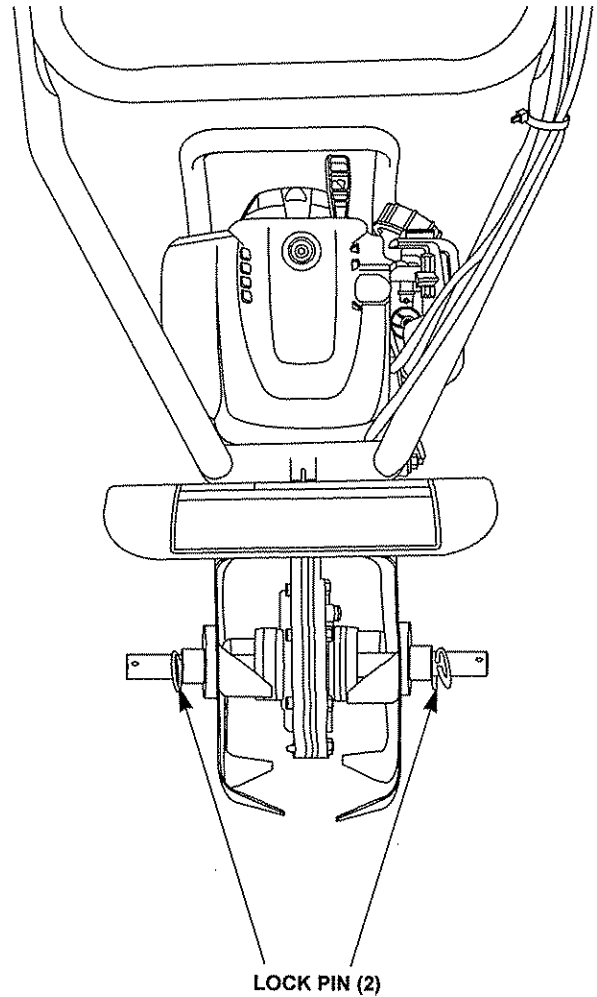

SERVICING YOUR TILLER

THE IMPORTANCE OF MAINTENANCE

Good maintenance is essential for safe, economical, and trouble-free operation. It will also help reduce air pollution.

WARNING

Improperly maintaining this tiller, or failure to correct a problem before operation, can cause a malfunction in which you can be seriously hurt or killed.

Always follow the inspection and maintenance recommendations and schedules in this owner's manual.

To help you properly care for your tiller, the following pages include a maintenance schedule, routine inspection procedures, and simple maintenance procedures using basic hand tools. Other service tasks that are more difficult, or require special tools, are best handled by professionals and are normally performed by a Honda technician or other qualified mechanic.

The maintenance schedule applies to normal operating conditions. If you operate your tiller under severe conditions, such as sustained high-load or high-temperature operation, or use it in unusually wet or dusty conditions, consult your servicing dealer for recommendations applicable to your individual needs and use.

Remember that your authorized Honda servicing dealer knows your tiller best and is fully equipped to maintain and repair it.

To ensure the best quality and reliability, use only new, genuine Honda parts or their equivalents for repair and replacement.

Maintenance, replacement, or repair of the emission control devices and systems may be performed by any engine repair establishment or individual, using parts that are "certified" to EPA standards.

MAINTENANCE SAFETY

Some of the most important safety precautions follow. However, we cannot warn you of every conceivable hazard that can arise in performing maintenance. Only you can decide whether or not you should perform a given task.

WARNING

Failure to properly follow maintenance instructions and precautions can cause you to be seriously hurt or killed.

Always follow the procedures and precautions in the owner's manual.

Safety Precautions

- Make sure the engine is off before you begin any maintenance or repairs. This will eliminate several potential hazards:
 - Carbon monoxide poisoning from engine exhaust. Be sure there is adequate ventilation whenever you operate the engine.
 - Burns from hot parts. Let the engine and exhaust system cool before touching.
 - Injury from moving parts. Do not run the engine unless instructed to do so.
- Read the instructions before you begin, and make sure you have the tools and skills required.
- To reduce the possibility of fire or explosion, be careful when working around gasoline. Use only a nonflammable solvent, not gasoline, to clean parts. Keep cigarettes, sparks, and flames away from all fuel-related parts.

MAINTENANCE SCHEDULE

REGULAR SERVICE PERIOD (3)		Before each use	First month or 10 Hrs	Every month or 10 Hrs	Every 3 months or 25 Hrs	Every 6 months or 50 Hrs	Every year or 100 Hrs	Every 2 years or after each 300 Hrs	Refer to page number
Engine oil	Check	O							18
	Change		O			O			
Air filter	Check	O							19
	Clean			O(1)					
Spark plug	Check						O		21
	Replace							O	
Throttle cable	Check	O							23
Cooling fins	Check	O				O			23
Spark arrester	Clean						O		22
Fuel tank	Clean						O		25
Fuel filter	Check						O		25
Clutch shoes	Check					O(2)			—
Idle speed	Check-Adjust							O(2)	23
Valve clearance	Check-Adjust							O(2)	—
Combustion chamber	Clean							O(2)	—
Nuts and bolts	Check (Retighten if necessary)	O							—
Transmission grease	Check				O				26
Fuel tubes	Check							O(2)	25

(1) Service more frequently when used in dusty areas.

(2) These items should be serviced by your servicing dealer, unless you have the proper tools and are mechanically proficient. Refer to the Honda shop manual for service procedures.

(3) Log hours of operation to determine proper maintenance intervals.

SERVICING YOUR TILLER

ENGINE

Engine Oil Level Check

Check the engine oil level before each use, or every 10 hours if operated continuously. Rest the tiller on a level surface, with the engine stopped and in an upright position.

1. Tip the tiller on its carry handlebar as shown.
2. Remove the oil filler cap/dipstick and wipe it clean.
3. Insert and remove the dipstick **without screwing it into the filler opening**. Check the oil level shown on the dipstick.
4. If the oil level is low, fill to the edge of the oil filler hole with the recommended oil (see page 19). To avoid overfilling or underfilling, be sure the engine is in a level position, as shown.

NOTICE

Running the engine with too little or too much oil can cause engine damage.

5. Screw in the oil filler cap/dipstick securely.

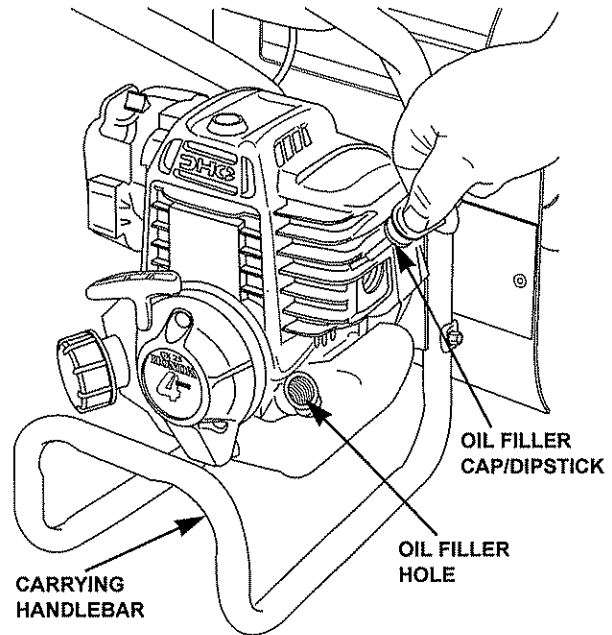

Engine Oil Change

Drain the used oil while the engine is warm. Warm oil drains quickly and completely.

1. Place a suitable container below the engine to catch the used oil.
2. Remove the oil filler cap/dipstick.
3. Tip the tiller to drain the used oil through the oil filler opening. Allow the used oil to drain completely.

Please dispose of used motor oil in a manner that is compatible with the environment. We suggest you take used oil in a sealed container to your local recycling center or service station for reclamation. Do not throw it in the trash, pour it on the ground or down a drain.

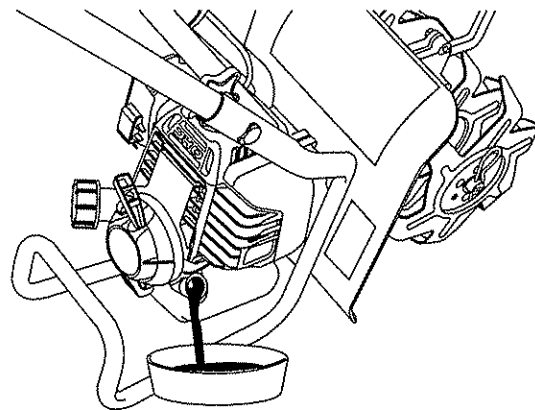

4. With the engine resting on the carrying handlebar on a level surface, fill to the edge of the oil filler hole with the recommended oil (see page 19). Do not overfill.
5. Screw in the filler cap/dipstick securely.

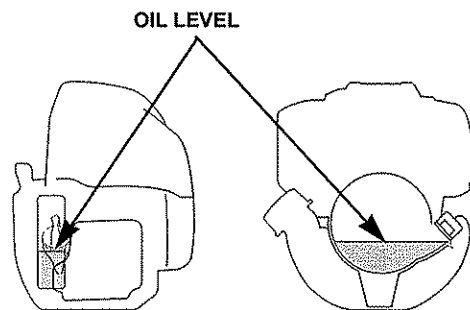

Engine Oil Recommendations

Oil is a major factor affecting performance and service life. Use 4-stroke automotive detergent oil.

SAE 10W-30 is recommended for general use. Other viscosities shown in the chart may be used when the average temperature in your area is within the recommended ranges.

The SAE oil viscosity and service classification are in the API label on the oil container. Honda recommends that you use API SERVICE category SJ (or later) oil with the "starburst" certification mark displayed on the container.

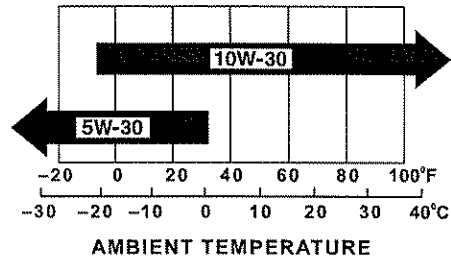

Air Filter Check

1. Move the choke lever to the CLOSED (N) position to prevent dirt from entering the engine.
2. Squeeze together the air cleaner upper tab at the top of the air cleaner cover to release it from its catch, then flip the cover down to remove it.
3. Check the air filter to be sure it is clean and in good condition.
4. If the air filter is dirty, clean it as described under *Air Filter Cleaning* (see page 20). Replace the air filter if it is damaged.

NOTICE

Operating the engine without an air filter, or with a damaged air filter, will allow dirt to enter the engine, causing rapid engine wear. This type of damage is not covered by the Distributor's Limited Warranty (see page 39).

5. Align the air filter with the air cleaner base as shown. Reinstall the air filter by locating the three air cleaner base pegs into the three air filter holes. Slide the air filter over the pegs until it is flush with the air cleaner base.

NOTICE

An improperly installed air filter will allow dirt to enter the engine, causing rapid engine wear. Make sure the air filter is properly installed and flush with the air cleaner base before installing the air cleaner cover.

6. Reinstall the air cleaner cover by hooking the two lower tabs on the bottom of the cover and snapping the upper tab into place.

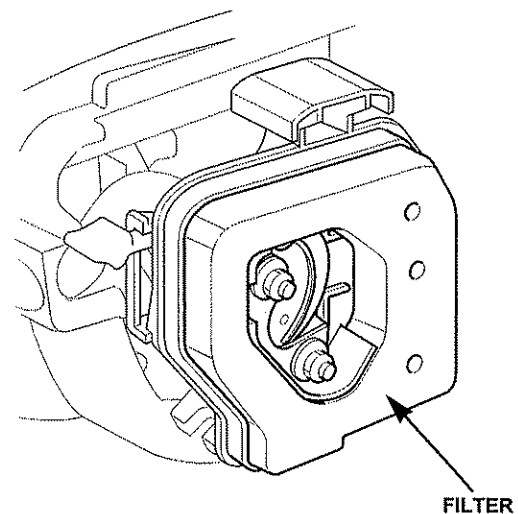
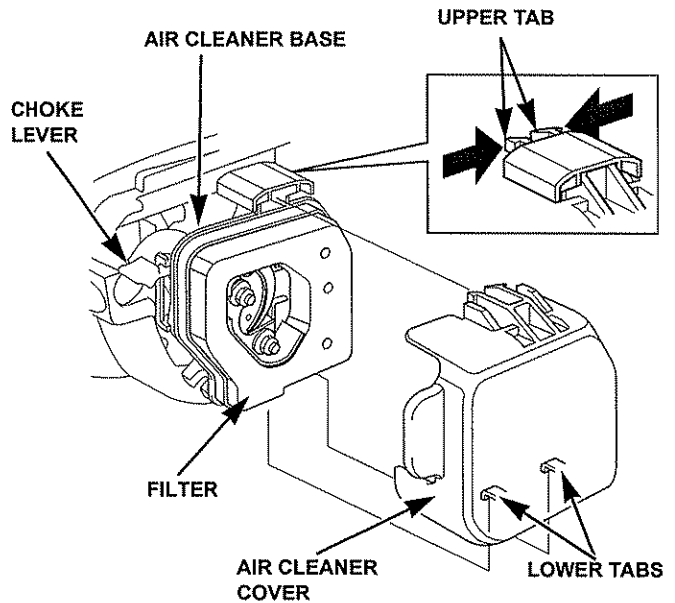

SERVICING YOUR TILLER

Air Filter Cleaning

A dirty air filter restricts air flow to the carburetor, reducing engine performance. If you operate the engine in very dusty areas, clean the air filter after each refueling.

1. Remove the air filter (see page 19).
2. Clean the air filter in warm soapy water, rinse, and allow it to dry thoroughly. Or, clean in nonflammable solvent and allow it to dry.
3. Dip the air filter in clean engine oil, then squeeze out all excess oil. The engine will be hard to start or will smoke when started if too much oil is left in the air filter.

NOTICE

Operating the engine with a dry air filter will allow dust to enter causing engine damage. The air filter must be oiled after cleaning.

4. Wipe dirt from the air cleaner base and cover using a moist rag. Be careful to prevent dirt from entering the carburetor.
5. Reinstall the air filter and air filter cover (see page 19).

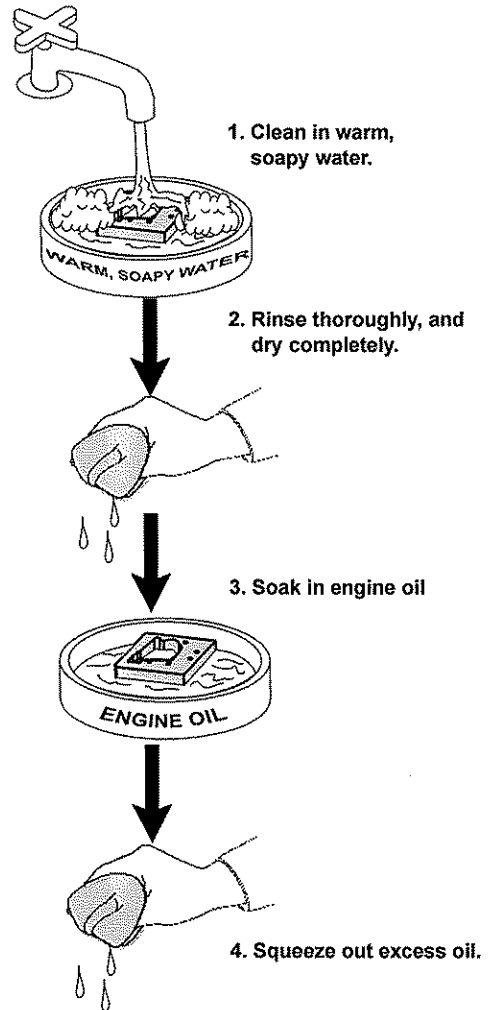

Spark Plug Service

Recommended spark plugs:
NGK – CM5H or CMR5H

NOTICE

Incorrect spark plugs can cause engine damage.

1. Loosen the captive 5 mm hex bolt with a 4 mm Allen wrench, then remove the fan cover.
2. Disconnect the spark plug cap, and remove any dirt from around the spark plug area.
3. Remove the spark plug with a 5/8-inch spark plug wrench.
4. Inspect the spark plug. Replace it if the electrodes are worn, or if the insulator is cracked, chipped, or fouled.

5. Measure the spark plug electrode gap with a suitable gauge.

Plug gap: 0.024 ~ 0.028 in (0.60 ~ 0.70 mm)

Correct the gap, if necessary, by carefully bending the side electrode.

6. Make sure the sealing washer is attached and install the spark plug carefully, by hand, to avoid cross-threading.
7. After the spark plug seats, tighten with a 5/8-inch spark plug wrench to compress the washer.

If reinstalling the used spark plug, tighten 1/8 ~ 1/4 turn after the spark plug seats. If installing a new spark plug, tighten 1/2 turn after the spark plug seats.

NOTICE

A loose spark plug can overheat and damage the engine. Overtightening the spark plug can damage the threads in the cylinder head.

8. Attach the spark plug cap.
9. Install the fan cover, and tighten the 5 mm hex bolt securely.

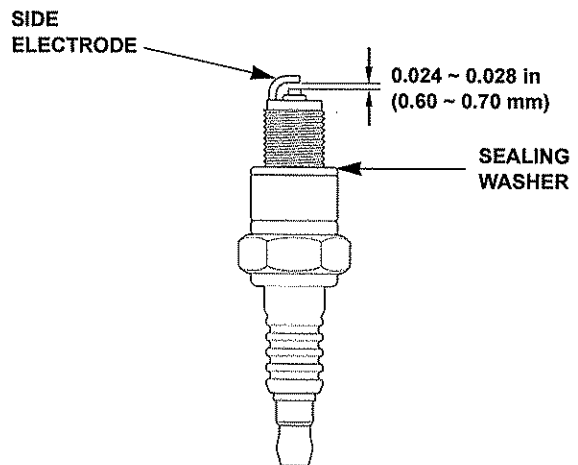
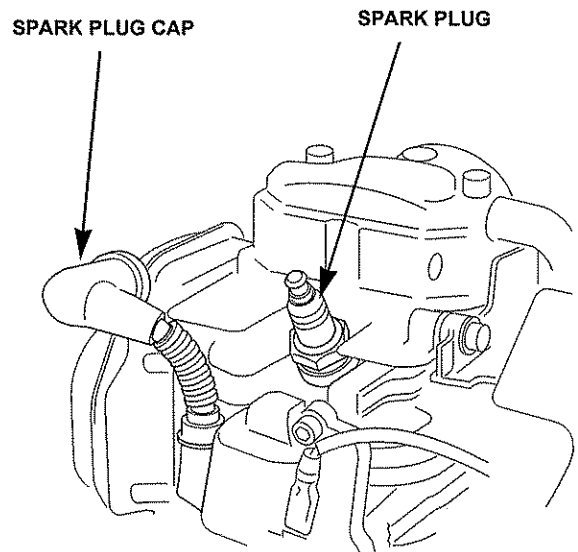
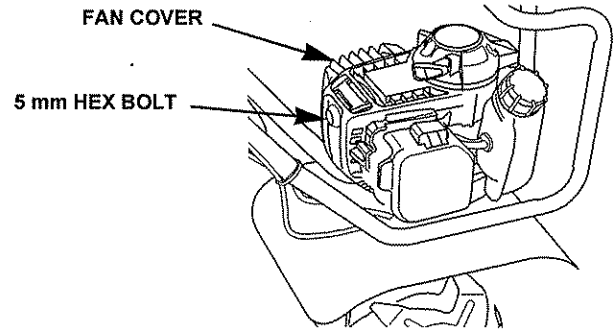

SERVICING YOUR TILLER

Spark Arrester Service (Optional)

The spark arrester must be serviced every 100 hours to keep it functioning as designed.

If the engine has been running, the muffler will be very hot. Allow the muffler to cool before servicing the spark arrester.

1. Loosen the 5 mm hex bolt, then remove the fan cover.
2. Remove the 3 x 6 mm self-tapping screw from the spark arrester, and remove the spark arrester from the muffler.

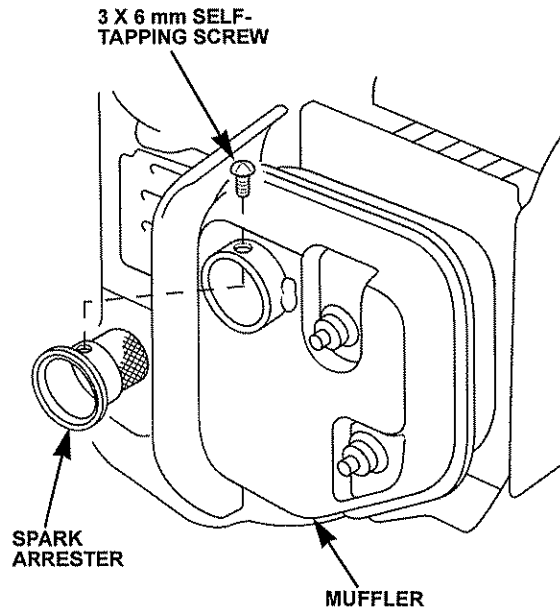

3. Use a brush to remove carbon deposits from the spark arrester screen. Be careful to avoid damaging the screen.
The spark arrester must be free of breaks and holes. Replace the spark arrester if it is damaged.
4. Install the spark arrester in the reverse order of disassembly.
5. Install the fan cover, and tighten the 5 mm hex bolt securely.

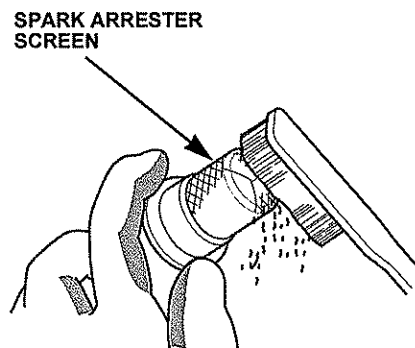

Cooling Fin Inspection

Inspect the engine cooling fins. You should clean out any dirt and debris if air is obstructed from flowing across the cooling fins.

1. Loosen the 5 mm hex bolt, then remove the fan cover.
2. Remove all dirt and debris from the cooling fins.
3. Install the fan cover, and tighten the 5 mm hex bolt securely.

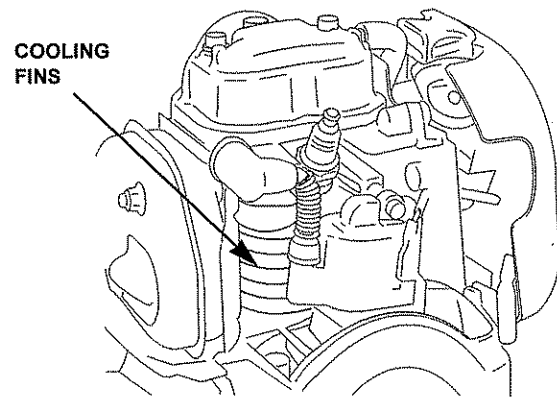

Throttle Cable Inspection

Verify that the throttle trigger operates smoothly, releases properly, and the throttle cable is undamaged. If there is visible damage, or if the throttle lever does not operate smoothly or release properly, take your tiller to your authorized Honda servicing dealer.

Check the freeplay at the end of the throttle lever.

Throttle Lever Freeplay: 3/16 ~ 5/16 inch (5 ~ 8 mm)

If adjustment is needed, use the *Throttle Cable Adjustment* procedure below.

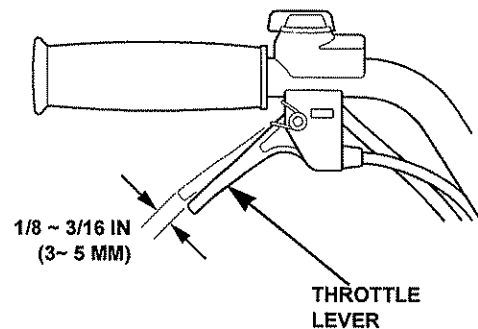

Carburetor Adjustment

A tachometer is required to adjust the idle speed. If you do not have one, take your tiller to an authorized Honda servicing dealer to perform idle speed adjustment.

1. Start the engine outdoors, and allow it to warm up to normal operating temperature.
2. Turn the throttle stop screw to obtain a stable idle, below the speed at which the tiller tines begin to turn.

Standard Idle Speed: 3,100 ± 200 rpm

3. Verify that the throttle lever free play is 3/16 ~ 5/16 inch (5 ~ 8 mm). If adjustment is needed, use the *Throttle Cable Adjustment* procedure below.

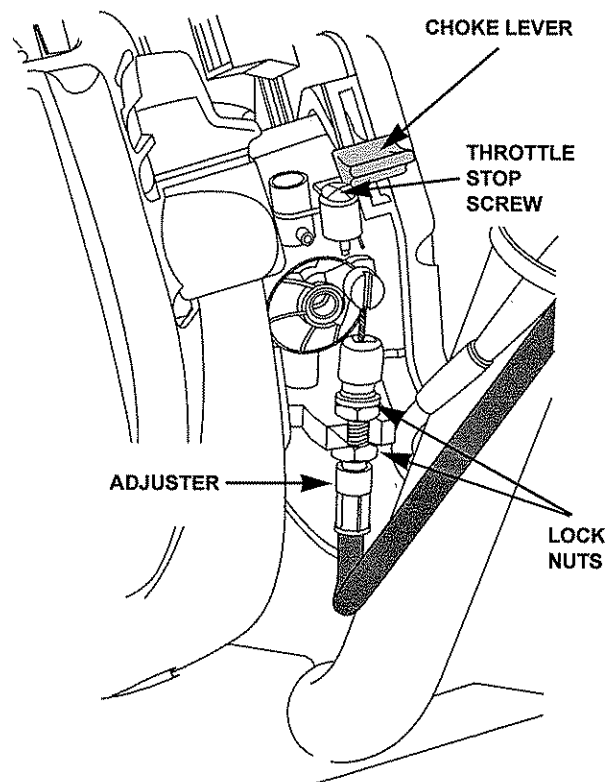

Throttle Cable Adjustment

1. Loosen the lock nuts with a 10 mm wrench, and move the adjuster in or out as required.

Throttle Lever Freeplay: 3/16 ~ 5/16 inch (5 ~ 8 mm)

2. Tighten the lock nuts and recheck throttle lever freeplay.

SERVICING YOUR TILLER

FUEL SYSTEM

Refueling

Fuel Tank Capacity: 0.6 US qt (1.2 US pt, 0.55 ℓ)

Check the fuel level by looking through the translucent fuel tank.

⚠ WARNING

Gasoline is highly flammable and explosive.

You can be burned or seriously injured when handling fuel.

- Stop the engine and keep heat, sparks, and flames away.
- Handle fuel only outdoors.
- Wipe up spills immediately.

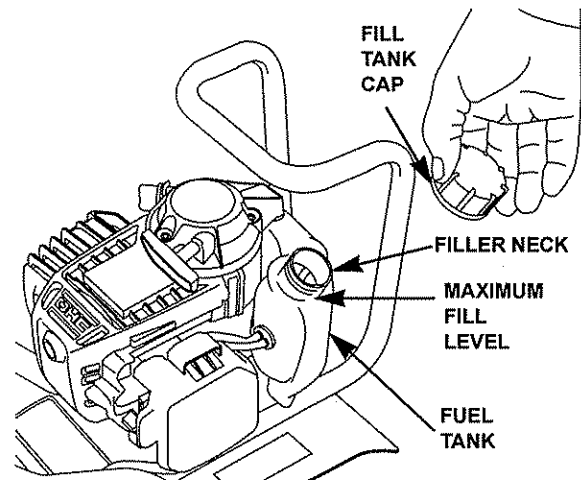

If the fuel level is low, refuel in a well-ventilated area with the engine stopped. If the engine has been running, allow it to cool first.

To refuel, set the tiller on level ground. Remove the fuel tank cap, and fill the tank with gasoline to the bottom of the filler neck. Refuel carefully to avoid spilling fuel. Do not overfill. There should not be fuel in the filler neck. After refueling, tighten the fuel tank cap securely. Never refuel the engine inside a building where gasoline fumes may reach flames or sparks. Keep gasoline away from appliance pilot lights, barbecues, electric appliances, power tools, etc.

Spilled fuel is not only a fire hazard, it causes environmental damage. Wipe up spills immediately.

Move at least 10 feet (3 meters) away from the fueling source location before starting the engine.

NOTICE

Fuel can damage paint and plastic. Be careful not to spill fuel when filling your fuel tank. Damage caused by spilled fuel is not covered under the Distributor's Limited Warranty (see page 39).

Fuel Recommendations

Use unleaded gasoline with a pump octane rating of 86 or higher.

This engine is certified to operate on unleaded gasoline. Unleaded gasoline produces fewer engine and spark plug deposits and extends exhaust system life.

Never use stale or contaminated gasoline or an oil/gasoline mixture. Avoid getting dirt or water in the fuel tank.

Occasionally you may hear a light "spark knock" or "pinging" (metallic rapping noise) while operating under heavy loads. This is no cause for concern.

If spark knock or pinging occurs at a steady engine speed, under normal load, change brands of gasoline. If spark knock or pinging persists, see an authorized Honda servicing dealer.

NOTICE

Running the engine with persistent spark knock or pinging can cause engine damage.

Running the engine with persistent spark knock or pinging is misuse, and the Distributor's Limited Warranty does not cover parts damaged by misuse (see page 39).

Fuel Tube Inspection

Check the fuel supply and return tubes, and replace any tube that is damaged, cracked, or leaking.

Refer to the Honda shop manual for tube replacement instructions, or take the tiller to an authorized Honda servicing dealer.

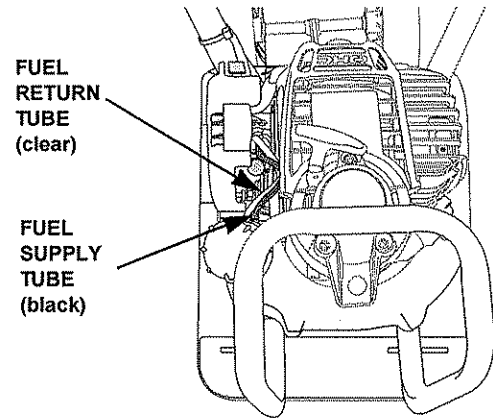

Fuel Filter and Fuel Tank Cleaning

1. Remove the fuel tank cap.
2. Tip the tiller as shown and empty the fuel tank into an approved gasoline container. Use a funnel to avoid spilling gasoline.
3. Pull the fuel filter out through the fuel filler neck by hooking the black fuel supply tube with a piece of wire, such as a partly straightened paper clip.
4. Inspect the fuel filter. If the fuel filter is dirty, wash it with nonflammable solvent. Be careful to avoid damaging the filter.
5. Replace the filter if it is damaged or excessively dirty.
6. Rinse sediment from the fuel tank with nonflammable solvent.
7. Insert the fuel filter in the fuel tank, and install the fuel tank cap.

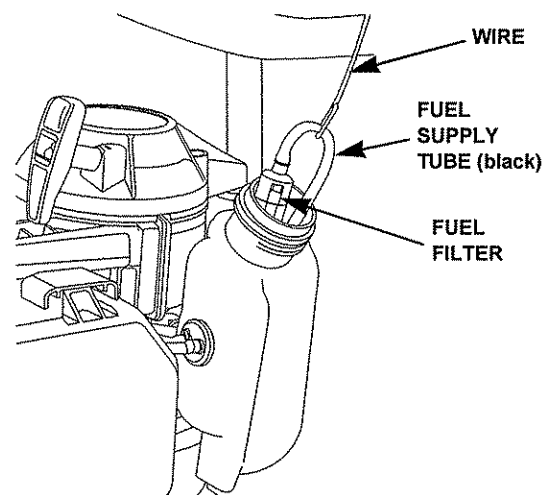
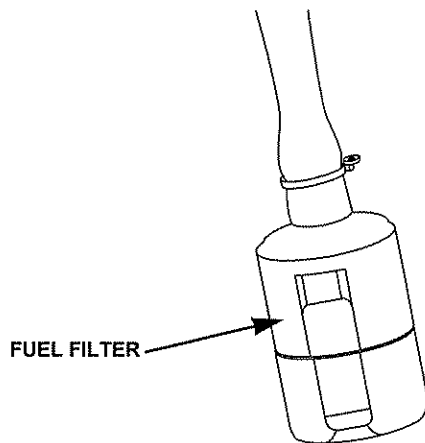
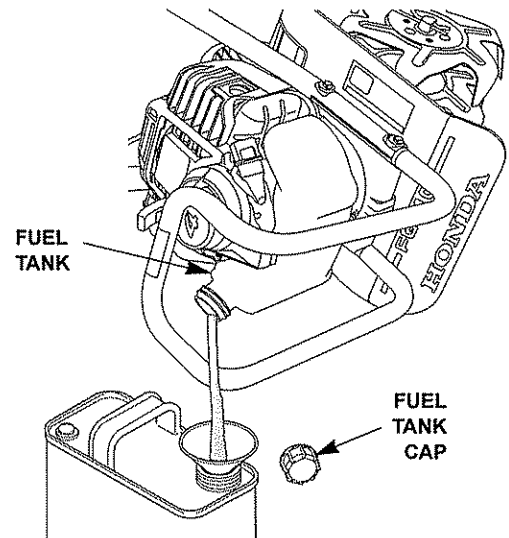

SERVICING YOUR TILLER

TRANSMISSION LUBRICATION

The transmission is pre-lubricated at the factory.

At the beginning of each tilling season, or after every 25 hours of use during the season, the transmission should be filled with grease.

Replacement grease should be a high quality petroleum based NLGI #2 general purpose grease usually available in disposable tubes at most hardware or automotive parts stores.

1. Place the tiller on the left side as shown.
2. Remove the lock pin from the right side tine shaft by turning it UP [a] and pulling it out [b] as shown. Wearing heavy gloves, remove both right side tines.
3. Remove the air vent screw and fill hole screw from the transmission.
4. Fill the transmission by using a grease gun or grease applicator at the fill hole screw opening. Push the gun or applicator against the opening so as to seal the nozzle of the gun or applicator against the casting embossment. Apply grease until grease begins to come out of the top air vent hole.
5. Reinstall the air vent screw and fill hole screw.
6. Clean the tine shaft and place a few drops of oil on the tine shaft before installing the tines.
7. Wear heavy gloves and reinstall the tines in the reverse order of removal.
8. Install the lock pin through the round side of the tine shaft hole [a], then turn it over [b] to lock it in place.

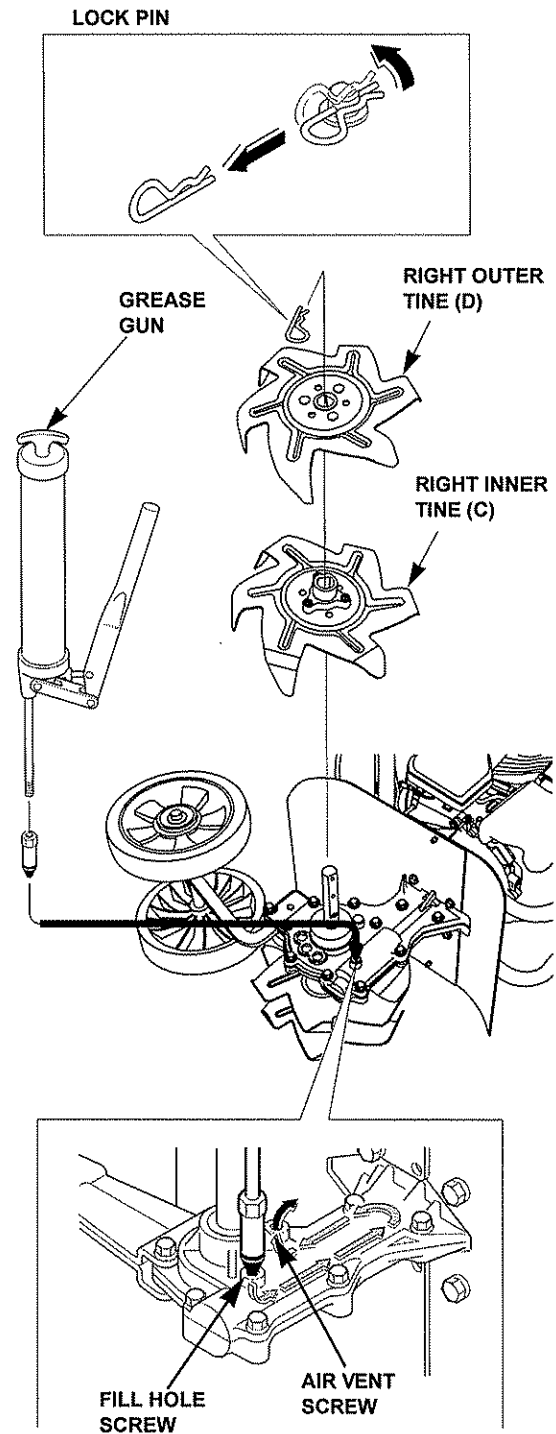

THE IMPORTANCE OF PROPER ASSEMBLY

Proper assembly is essential to operator safety and the reliability of the machine. Any error or oversight made by the person assembling and servicing a unit can result in faulty operation, damage to the machine, or injury to the operator.

WARNING

Improper assembly can cause an unsafe condition that can lead to serious injury or death.

Follow the procedures and precautions in the assembly instructions carefully.

Some of the most important safety precautions are given below. However, we cannot warn you of every conceivable hazard that can arise in performing this assembly. Only you can decide whether or not you should perform a given task.

WARNING

Failure to properly follow instructions and precautions can cause you to be seriously hurt or killed.

Follow the procedures and precautions in this manual carefully.

IMPORTANT SAFETY PRECAUTIONS

- Make sure you have a clear understanding of all basic shop safety practices and that you are wearing appropriate clothing and safety equipment. When performing this assembly, be especially careful of the following:
 - Read the instructions before you begin and be sure you have the tools and skills required to perform the tasks safely.
- Make sure the engine is off before you begin any maintenance or repairs. This will help eliminate several potential hazards:
 - Carbon monoxide poisoning from engine exhaust.**
Be sure there is adequate ventilation whenever you run the engine.
 - Burns from hot parts.**
Let the engine and exhaust system cool before touching.
 - Injury from moving parts.**
Do not run the engine unless the instruction tells you to do so. Even then, keep your hands, fingers, and clothing away from moving parts. Do not run the engine when any protective guard or shield is removed.
- To reduce the possibility of a fire or explosion, be careful when working around gasoline or batteries. Use only a nonflammable solvent, not gasoline, to clean parts. Keep all cigarettes, sparks, and flames away from all fuel-related parts.

ASSEMBLY

UNPACKING

1. Carefully remove the tiller and loose parts bag from the carton.
The loose parts bag contains this owner's manual, the drag bar, and a bottle of 10W-30 oil.
2. Unfold the tiller upper handle to the operating position as shown. Be careful not to crimp or pinch the engine switch wires and throttle cable.
3. Tighten the handle knobs to secure the handle in the correct operating position.

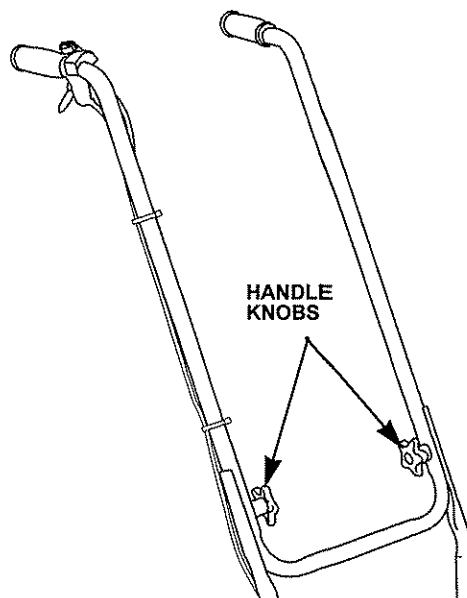

ADDING OIL

NOTICE

The tiller is shipped from the factory with no oil in the engine. Add oil from the bottle of oil supplied with the tiller before attempting to start the engine.

1. Working on a level surface, tip the tiller on its carrying handlebar as shown.
2. Remove the oil filler cap/dipstick.
3. Slowly add the recommended oil (included in the box) to the bottom edge of the oil fill hole. Do not overfill, as the engine oil tank capacity is small.

NOTICE

Running the engine with too little or too much oil can cause engine damage.

4. Screw in the oil filler cap/dipstick securely.

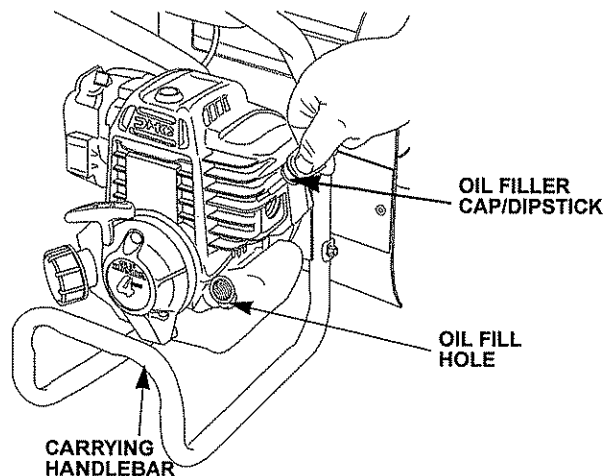

BEFORE OPERATION

Before using the tiller, all tiller operators must read the following chapters and sections:

- **TILLER SAFETY** (see page 4).
- **CONTROLS** (see page 7).
- **BEFORE OPERATION** (see page 10).
- **OPERATION** (see page 12).
- **MAINTENANCE SCHEDULE** (see page 17).

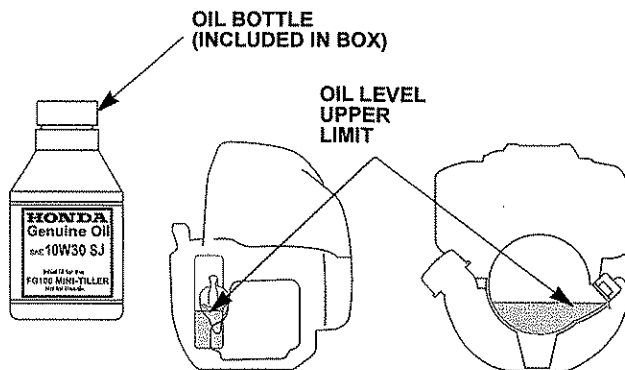

STORAGE PREPARATION

Proper storage preparation is essential for keeping your tiller trouble free and looking good. The following steps will help to keep rust and corrosion from impairing your tiller's function and appearance, and will make the engine easier to start when you use the tiller again.

Cleaning

1. Wash the tiller, including the area around the tiller tines.
2. Wash the engine by hand, and be careful to prevent water from entering the air cleaner.

NOTICE

Using a garden hose or pressure washing equipment can force water into the air cleaner. Water in the air cleaner will soak the filter and can enter the carburetor or engine, causing damage.

3. Water on a hot engine can cause damage. If the engine has been running, allow it to cool for at least 1/2 hour before washing.
4. If using a garden hose or pressure washing equipment to clean the tiller, be careful to avoid getting water into controls and cables, or anywhere near the engine air cleaner or muffler opening.
5. After washing the tiller, wipe dry all accessible surfaces.
6. Start the engine outdoors, and let it run until it reaches normal operating temperature to evaporate any water remaining on the engine.
7. Stop the engine and allow it to cool.
8. After the tiller is clean and dry, touch up any damaged paint, and coat other areas that may rust with a light film of oil. Lubricate the throttle cable core with a silicone spray lubricant.

Fuel

Gasoline will oxidize and deteriorate in storage. Old gasoline will cause hard starting, and it leaves gum deposits that restrict the fuel system. If the gasoline in your tiller deteriorates during storage, you may need to have the carburetor and other fuel system components serviced or replaced.

The length of time that gasoline can be left in your fuel tank and carburetor without causing functional problems will vary with such factors as gasoline blend, storage temperatures, and whether the fuel tank is partially or completely filled. The air in a partially filled fuel tank promotes fuel deterioration. Very warm storage temperatures accelerate fuel deterioration. Fuel deterioration problems may occur within a few months, or even less if the gasoline was not fresh when you filled the fuel tank.

The *Distributors Limited Warranty* (see page 39) does not cover fuel system damage or engine performance problems resulting from neglected storage preparation.

You can extend fuel storage life by adding a gasoline stabilizer that is formulated for that purpose, or you can avoid fuel deterioration problems by draining the fuel tank and carburetor.

Adding Fuel Stabilizer To Extend Fuel Storage Life

When adding a fuel stabilizer, fill the fuel tank with fresh gasoline. If only partially filled, air in the tank will promote fuel deterioration during storage. If you keep a container of gasoline for refueling, be sure that it contains only fresh gasoline.

Add fuel stabilizer following the manufacturer's instructions.

After adding a fuel stabilizer, run the engine outdoors for 10 minutes to be sure that treated gasoline has replaced the untreated gasoline in the carburetor.

STORAGE

Draining the Fuel Tank and Carburetor

1. Drain the fuel from the fuel tank to a suitable container (see page 25).
2. Start the engine (see page 13) and allow it to run until the engine stops.

WARNING

Gasoline is highly flammable and explosive.

You can be burned or seriously injured when handling fuel.

- Stop the engine and keep heat, sparks, and flames away.
- Handle fuel only outdoors.
- Wipe up spills immediately.

Engine Oil

Change the engine oil (see page 18).

Carburetor & Air Cleaner

Clean the air filter (see page 20) and move the choke lever to the CLOSED () position.

Engine Cylinder

Remove the spark plug (see page 21). Pour 1/4 tablespoon (1 ~ 3 cc) of clean engine oil into the cylinder. Pull the starter rope several times to distribute the oil in the cylinder. Reinstall the spark plug. Pull the starter rope slowly until resistance is felt then return the starter grip gently. This closes the valves so moisture cannot enter.

STORAGE PRECAUTIONS

If your tiller will be stored with gasoline in the fuel tank and carburetor, it is important to reduce the hazard of gasoline vapor ignition. Select a well-ventilated storage area away from any appliance that operates with a flame, such as a furnace, water heater, or clothes dryer. Also avoid any area with a spark-producing electric motor, or where power tools are operated.

If possible, avoid storage areas with high humidity, because that promotes rust and corrosion.

With the engine and exhaust system cool, cover the tiller to keep out dust. A hot engine and exhaust system can ignite or melt some materials. Do not use sheet plastic as a dust cover. A nonporous cover will trap moisture, promoting rust and corrosion.

REMOVAL FROM STORAGE

Check your tiller as described in the *BEFORE OPERATION* chapter of this manual (see page 10). If the fuel was drained during storage preparation, fill the tank with fresh gasoline. If you keep a container of gasoline for refueling, be sure that it contains only fresh gasoline. Gasoline oxidizes and deteriorates over time, causing hard starting.

If the cylinder was coated with oil during storage preparation, the engine will smoke briefly at startup. This is normal.

TRANSPORTING

BEFORE LOADING

If the engine has been running, allow it to cool for at least 15 minutes before loading the tiller on the transport vehicle. A hot engine and exhaust system can burn you and can ignite some materials.

1. Turn the engine switch to the OFF position.
2. Make sure the fuel cap is securely tightened.
3. Install the wheels to provide added stability when transporting (see page 9).

LOADING

If necessary, loosen the handlebar knobs so that the tiller upper handlebar can be collapsed forward over the engine. Be careful that the throttle cable and engine switch wire are not pinched or bent when collapsing the upper handlebar.

Secure the tiller by tying around the lower handlebars just in front and back of the engine.

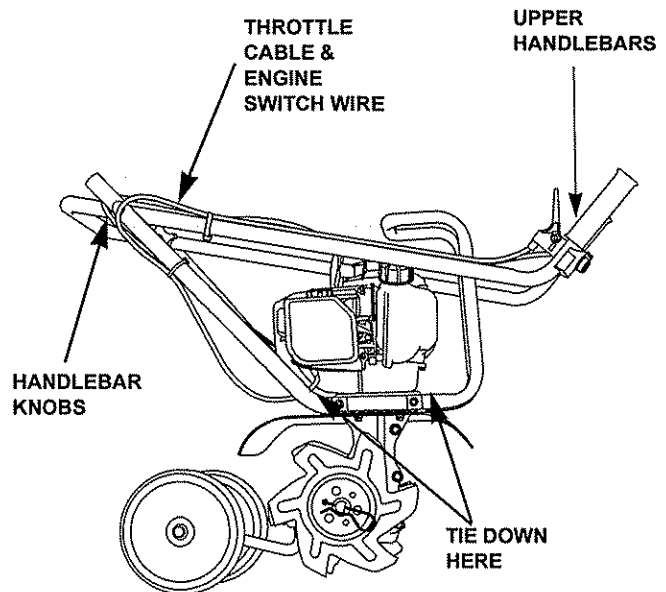

TAKING CARE OF UNEXPECTED PROBLEMS

Engine Will Not Start

Possible Cause	Correction
Ignition switch OFF.	Turn engine switch ON (page 13).
Choke lever not in CLOSED (N) position (cold engine).	Move lever to CLOSED (N) position (page 13).
Out of fuel.	Add fuel and press priming bulb to fill carburetor (page 13).
Bad fuel, tiller stored without treating or draining gasoline, refueled with bad gasoline.	Drain fuel tank. Refuel with fresh gasoline (page 25).
Spark plug faulty, fouled, or has incorrect gap.	Gap or replace the spark plug (page 21).
Fuel filter restricted, carburetor malfunction, ignition malfunction, valves stuck, etc.	Have an authorized Honda servicing dealer replace or repair faulty components as needed.

Low Power or Engine Speed Won't Increase

Possible Cause	Correction
Air filter dirty or restricted.	Check, clean or replace the air filter (page 19, 20).
Fuel filter dirty or restricted.	Check, clean or replace the fuel filter (page 25).
Throttle cable out of adjustment, broken, or bent.	Adjust or replace the cable if necessary (page 23).

Tiller Tines (or Attachment) Won't Stop Turning When Throttle is at SLOW Position

Possible Cause	Correction
Faulty throttle control or cable; throttle cable out of adjustment or bent.	Check throttle control parts, adjust or replace cable if necessary (page 23).
Idle speed is too high.	Have an authorized Honda servicing dealer adjust idle speed.
Clutch springs worn or clutch system faulty.	Have an authorized Honda servicing dealer replace clutch springs or replace or repair other clutch system parts.

TECHNICAL & CONSUMER INFORMATION

This chapter contains important information about serial number locations; high altitude operation, oxygenated fuels, and emissions control systems.

SERIAL NUMBER LOCATIONS

Record the frame serial number, engine serial number, and date of purchase in the spaces below. You will need this information when ordering parts and when making technical or warranty inquiries.

Engine Serial Number: GCAAM – _____ Frame Serial Number: FAAA – _____

Date of purchase: _____

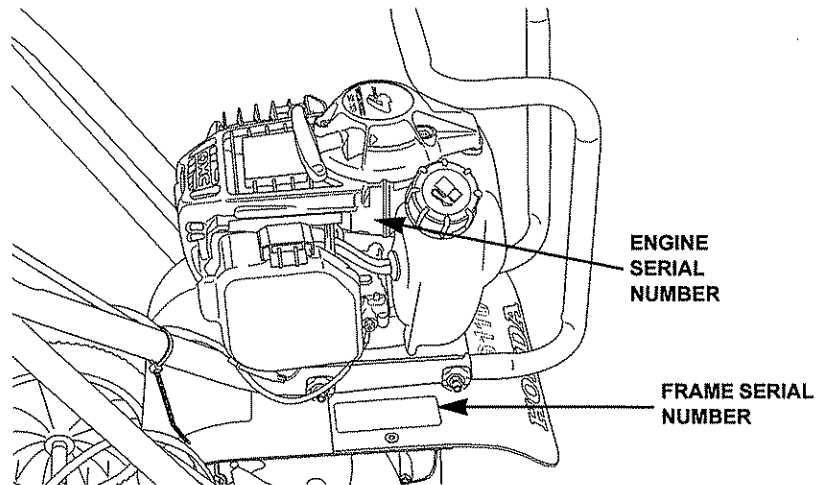

CARBURETOR MODIFICATIONS FOR HIGH ALTITUDE OPERATION

At high altitude, the standard carburetor air-fuel mixture will be too rich. Performance will decrease, and fuel consumption will increase. A very rich mixture will also foul the spark plug and cause hard starting. Operation at an altitude that differs from that at which this engine was certified, for extended periods of time, may increase emissions.

High altitude performance can be improved by specific modifications to the carburetor. If you always operate your tiller at altitudes above 5,000 feet (1,500 meters), have your servicing dealer perform this carburetor modification. This engine, when operated at high altitude, with carburetor modifications for high altitude use, will meet each emission standard throughout its useful life.

Even with carburetor modification, engine horsepower will decrease about 3.5% for each 1,000-foot (300-meter) increase in altitude. The effect of altitude on horsepower will be greater than this if no carburetor modification is made.

NOTICE

When the carburetor has been modified for high altitude operation, the air-fuel mixture will be too lean for low altitude use. Operation at altitudes below 5,000 feet (1,500 meters) with a modified carburetor may cause the engine to overheat and result in serious engine damage. For use at low altitudes, have your servicing dealer return the carburetor to original factory specifications.

TECHNICAL & CONSUMER INFORMATION

OXYGENATED FUELS

Some conventional gasolines are being blended with alcohol or an ether compound. These gasolines are collectively referred to as oxygenated fuels. To meet clean air standards, some areas of the USA and Canada use oxygenated fuels to help reduce emissions. If you use an oxygenated fuel, be sure it is unleaded and meets the minimum octane rating requirement. Before using an oxygenated fuel, try to confirm the fuel's contents. Some states/provinces require this information to be posted on the pump.

The following are the EPA approved percentages of oxygenates:

- ETHANOL** ——— (ethyl or grain alcohol) **10% by volume**
You may use gasoline containing up to 10% ethanol by volume. Gasoline containing ethanol may be marketed under the name "Gasohol."
- MTBE** ————— (Methyl Tertiary Butyl Ether) **15% by volume**
You may use gasoline containing up to 15% MTBE by volume.
- METHANOL**——— (methyl or wood alcohol) **5% by volume**
You may use gasoline containing up to 5% methanol by volume, as long as it also contains cosolvents and corrosion inhibitors to protect the fuel system. Gasoline containing more than 5% methanol by volume may cause starting and/or performance problems. It may also damage metal, rubber, and plastic parts of your fuel system.

If you notice any undesirable operating symptoms, try another service station or switch to another brand of gasoline. Fuel system damage or performance problems resulting from the use of an oxygenated fuel containing more than the percentages of oxygenates mentioned above are not covered under warranty.

EMISSIONS CONTROL SYSTEM INFORMATION

Source of Emissions

The combustion process produces carbon monoxide, oxides of nitrogen, and hydrocarbons. Control of hydrocarbons and oxides of nitrogen is very important because, under certain conditions, they react to form photochemical smog when subjected to sunlight. Carbon monoxide does not react in the same way, but it is toxic.

Honda utilizes lean carburetor settings and other systems to reduce the emissions of carbon monoxide, oxides of nitrogen, and hydrocarbons.

The U.S., California Clean Air Act and Environment Canada

EPA, California and Canadian regulations require all manufacturers to furnish written instructions describing the operation and maintenance of emissions control systems.

The following instructions and procedures must be followed in order to keep the emissions from your Honda engine within the emissions standards.

Tampering and Altering

Tampering with or altering the emissions control system may increase emissions beyond the legal limit. Among those acts that constitute tampering are:

Removal or alteration of any part of the intake, fuel, or exhaust systems.

Altering or defeating the speed-adjusting mechanism to cause the engine to operate outside its design parameters.

Problems That May Affect Emissions

If you are aware of any of the following symptoms, have your engine inspected and repaired by your servicing dealer.

- Hard starting or stalling after starting
- Rough idle
- Misfiring or backfiring under load
- Afterburning (backfiring)
- Black exhaust smoke or high fuel consumption

Replacement Parts

The emissions control systems on your new Honda engine were designed, built, and certified to conform with EPA, California and Canadian emissions regulations. We recommend the use of genuine Honda parts whenever you have maintenance done. These original-design replacement parts are manufactured to the same standards as the original parts, so you can be confident of their performance. The use of replacement parts that are not of the original design and quality may impair the effectiveness of your emissions control system.

A manufacturer of an aftermarket part assumes the responsibility that the part will not adversely affect emissions performance. The manufacturer or rebuilder of the part must certify that use of the part will not result in a failure of the engine to comply with emissions regulations.

Maintenance

Follow the MAINTENANCE SCHEDULE on page 17. Remember this schedule is based on the assumption that your machine will be used for its designed purpose. Sustained high-load or high-temperature operation, or use in unusually wet or dusty conditions, will require more frequent service.

TECHNICAL & CONSUMER INFORMATION

Air Index

An Air Index Information hang tag/label is applied to engines certified to an emission durability time period in accordance with the requirements of the California Air Resources Board.

The bar graph is intended to provide you, our customer, the ability to compare the emissions performance of available engines. The lower the Air Index, the less pollution.

The durability description is intended to provide you with information relating the engine's emission durability period. The descriptive term indicates the useful life period for the engine's emission control system. See your *Emission Control System Warranty* for additional information (see page 41).

Descriptive Term	Applicable to Emissions Durability Period
Moderate	50 hours (0–65 cc)
	125 hours (greater than 65 cc)
Intermediate	125 hours (0–65 cc)
	250 hours (greater than 65 cc)
Extended	300 hours (0–65 cc)
	500 hours (greater than 65 cc)

The Air Index Information hang tag/label must remain on the trimmer/brush cutter until it is sold. Remove the hang tag before operating the trimmer/brush cutter

SPECIFICATIONS

ENGINE	
Model	GX25
Type	4-stroke, overhead cam, single cylinder
Description code	GCAAM
Displacement	1.5 cu in (25 cc)
Bore & stroke	1.4 x 1.0 in (35 x 26 mm)
Maximum horsepower	1.1 hp (0.81 kW) at 7,000 rpm
Maximum torque	0.94 lb•ft (1.25 N•m, 0.13 kgf•m) at 5,000 rpm
Compression ratio	8.0:1
Fuel consumption*	0.559 lb/HPh (340 g/kWh, 250 g/HPh)
Cooling system	Forced-air
Ignition system	Transistorized magneto
Ignition timing	30° B.T.D.C. (Fixed)
Spark plug	CMR5H (NGK)
Carburetor	Diaphragm type
Air cleaner	Semi-dry type
Lubrication system	Oil mist
Oil capacity	2.7 US oz (80 cc, 2.8 Imp oz)
Recommended operating ambient temperature	23°F ~ 104°F (-5°C ~ 40°C)
Starting system	Recoil starter
Stopping system	Ignition primary circuit ground
Fuel used	Unleaded gasoline with a pump octane rating of 86 or higher
Fuel tank capacity	0.14 US gal (0.55 ℓ, 0.12 Imp gal)
PTO shaft rotation	Counterclockwise (from PTO shaft side)

* Actual fuel consumption will vary depending on engine load conditions.

TECHNICAL & CONSUMER INFORMATION

TILLER			
Model		FG110 A	
Description code		FAAA	
Length x width x height		40.9 x 14.5 x 39.4 in (1038 x 368 x 1000 mm)	
Weight	Dry	With drag bar	28.6 lb (13 kg)
		With wheels	30.6 lb (13.9 kg)
	Wet	With drag bar	29.9 lb (13.6 kg)
		With wheels	31.9 lb (14.5 kg)
Drive clutch		Centrifugal mechanical	
Drive clutch engagement speed		4,200 ± 200 rpm	
Tilling width		9 in (230 mm)	
Tilling depth		8 in (203 mm)	
Transmission drive		Worm gear	
Tine number		4 (6 teeth per tine)	

TUNEUP

Spark plug gap	0.024 ~ 0.028 in (0.6 ~ 0.7 mm)	See page 21.
Idle speed	3,100 ± 200 rpm	See page 23.
Valve clearance (cold)	Intake 0.08 ± 0.02 mm Exhaust 0.11 ± 0.02 mm	See shop manual.
Other specifications	No other adjustments needed.	

CONSUMER INFORMATION

Find an Authorized Honda Servicing Dealer in Your Area

Call (800) 426-7701 or visit the Dealer Locator section of the Honda Power Equipment World Wide Web site:

www.hondapowerequipment.com/dealer

Customer Service Information

Honda Power Equipment dealership personnel are trained professionals. They should be able to answer any question you may have. If you encounter a problem that your dealer does not solve to your satisfaction, please discuss it with the dealership's management. The Service Manager or General Manager can help. Almost all problems are solved in this way.

If you are dissatisfied with the decision made by the dealership's management, contact the Honda Power Equipment Customer Relations Office.

You can write to:

American Honda Motor Co., Inc.
Power Equipment Division
Customer Relations Office
4900 Marconi Drive
Alpharetta, GA 30005-8847

Or telephone: (770) 497-6400
weekdays, 8:30 a.m. - 5:00 p.m. EST

TECHNICAL & CONSUMER INFORMATION

When you call or write, please provide us the following information:

- Model and serial numbers (tiller and engine)
- Name of the dealer who sold you the tiller
- Name and address of the dealer who services your tiller
- Date of purchase
- Your name, address, and telephone number
- A detailed description of the problem

Honda Publications

These publications will give you additional information for maintaining and repairing your tiller. You may order them from your Honda dealer. There is a shop manual, which covers complete maintenance and overhaul procedures. It is intended to be used by a skilled technician. There is also a parts catalog that provides a complete, illustrated parts list.

Replacement Parts, Optional Equipment, and Service Items

Contact an authorized Honda servicing dealer to purchase genuine, original Honda items for your tiller.

Replacement Parts

Description	Part Number
Air filter	17211-ZOH-800
Spark plug (NGK)	31915-ZOH-003
Tine: Right Outer	72462-V25-000
Tine: Right Inner	72470-V25-000
Tine: Left Outer	72466-V25-000
Tine: Left Inner	72475-V25-000

Service Items

Description	Part Number	Notes
SAE 10W-30 engine oil	08209-10W30	
Silicone spray	08209-0001	Lubricates throttle cable core
Fuel stabilizer	08732-0001	For long term storage
Matte black touch-up paint (aerosol can)	08707-NH105	For handlebar only

Optional Equipment

Below is a list of available optional attachments to enhance the versatility of your tiller. Apply anti-seize to the tine shaft to make removing and installing the attachments easier.

Description	Part Number	Notes
Digging Tines Attachment	06726-V25-000	Four digging tines that are designed to cut through sod and hard compacted soil or grass covered areas.
Aerator Attachment	06727-V25-000	Four 10-tooth, 8-1/2 inch heavy gauge tempered steel aerating tines that make slits in the soil. These slits allow water, air, and the proper nutrients to reach the grass roots.
Border/Edger Attachment	06728-V25-000	A 10-tooth, 8-1/2 inch edger tine of heavy gauge tempered steel that neatly edges your garden patio, walkways, driveways and flower beds
De-Thatcher Attachment	06729-V25-000	Two de-thatching assemblies containing three gangs of 12 spring steel combing fingers that cleanly de-thatch your lawn for healthier turf.

TECHNICAL & CONSUMER INFORMATION

Distributors Limited Warranty

PRODUCTS COVERED BY THIS WARRANTY	LENGTH OF WARRANTY: (from date of original retail purchase)	
	Noncommercial/Nonrental	Commercial/Rental
FG110 Mini-Tillers	24 months	3 months

To Qualify for this Warranty:

The product must be purchased in the United States, Puerto Rico, or the U.S. Virgin Islands from American Honda or a dealer authorized by American Honda to sell those products. This warranty applies to the first retail purchaser and each subsequent owner during the applicable warranty time period.

What American Honda will Repair or Replace Under Warranty:

American Honda will repair or replace, at its option, any part that is proven to be defective in material or workmanship under normal use during the applicable warranty time period. Warranty repairs and replacements will be made without charge for parts or labor. Anything replaced under warranty becomes the property of American Honda Motor Company, Inc. All parts replaced under warranty will be considered as part of the original product and any warranty on those parts will expire coincident with the original product warranty.

To Obtain Warranty Service:

You must take the Honda FG110 Mini-Tiller and proof of original retail purchase date, at your expense, to any Honda Power Equipment dealer in the United States, Puerto Rico, or the U.S. Virgin Islands who is authorized to service that product, during the dealer's normal business hours. If you are unable to obtain warranty service, or are dissatisfied with the warranty service you receive, take the following steps: First, contact the owner of the dealership involved; normally this should resolve the problem. However, if you should require further assistance, write or call the Power Equipment Customer Relations Department of American Honda Motor Co., Inc. Refer to page 37 for contact information.

Exclusions: THIS WARRANTY DOES NOT EXTEND TO PARTS AFFECTED OR DAMAGED BY ACCIDENT AND/OR COLLISION, NORMAL WEAR, FUEL CONTAMINATION, USE IN AN APPLICATION FOR WHICH THE PRODUCT WAS NOT DESIGNED OR ANY OTHER MISUSE, NEGLIGENCE, INCORPORATION OR USE OF UNSUITABLE ATTACHMENTS OR PARTS, UNAUTHORIZED ALTERATION, OR ANY CAUSES OTHER THAN DEFECTS IN MATERIAL OR WORKMANSHIP OF THE PRODUCT.

TILLER TINES ARE SPECIFICALLY NOT WARRANTED AGAINST DAMAGE, INCLUDING BUT NOT LIMITED TO, ABRASIVE DAMAGE.

Disclaimer of Consequential Damage and Limitation of Implied Warranties:

AMERICAN HONDA DISCLAIMS ANY RESPONSIBILITY FOR LOSS OF TIME OR USE OF THE PRODUCT, TRANSPORTATION, COMMERCIAL LOSS, OR ANY OTHER INCIDENTAL OR CONSEQUENTIAL DAMAGE. ANY IMPLIED WARRANTIES ARE LIMITED TO THE DURATION OF THIS WRITTEN LIMITED WARRANTY.

Some states do not allow limitations on how long an implied warranty lasts and/or do not allow the exclusion or limitation of incidental or consequential damages, so the above exclusions and limitations may not apply to you.

This warranty gives you specific legal rights, and you may also have other rights which vary from state to state.

TECHNICAL & CONSUMER INFORMATION

Accessories, Replacement Parts, and Apparel Warranty

PRODUCTS COVERED BY THIS WARRANTY	LENGTH OF WARRANTY: (from date of original retail purchase)	
	Noncommercial/Nonrental	Commercial/Rental
Accessories	24 months	3 months
Replacement Parts	6 months	3 months
Apparel	6 months	3 months

To Qualify for this Warranty:

1. The accessories, replacement parts, or apparel must be purchased in the United States, Puerto Rico, or the U.S. Virgin Islands from American Honda or a dealer authorized by American Honda to sell those products.
2. You must be the first retail purchaser. This warranty is not transferable to subsequent owners.

What American Honda will Repair or Replace Under Warranty:

American Honda will repair or replace, at its option, any power equipment accessories, replacement parts, or apparel that are proven to be defective in material or workmanship under normal use during the applicable warranty time period. Anything replaced under warranty becomes the property of American Honda Motor Company, Inc. All parts replaced under warranty will be considered as part of the original product and any warranty on those parts will expire coincident with the original product warranty.

Accessories and replacement parts, installed by a dealer who is authorized by American Honda to sell them, will be repaired or replaced under warranty without charge for parts or labor. If installed by anyone else, accessories and replacement parts will be repaired or replaced under warranty without charge for parts, but any labor charges will be the responsibility of the purchaser.

Apparel will be repaired or replaced under warranty without any charge.

To Obtain Warranty Service:

You must take the Honda Power Equipment accessory, replacement part, apparel or the power equipment on which the accessory or replacement part is installed, and proof of purchase, at your expense, to any Honda Power Equipment dealer in the United States, Puerto Rico, or the U.S. Virgin Islands who is authorized to service that product, during the dealer's normal business hours. If you are unable to obtain warranty service, or are dissatisfied with the warranty service you receive, take the following steps: First, contact the owner of the dealership involved; normally this will resolve the problem. However, if you should require further assistance, write or call the Power Equipment Customer Relations Department of American Honda Motor Co., Inc. Refer to page 37 for contact information.

Exclusions:

THIS WARRANTY DOES NOT EXTEND TO ACCESSORIES, PARTS, OR APPAREL AFFECTED OR DAMAGED BY ACCIDENT AND/OR COLLISION, NORMAL WEAR, USE IN AN APPLICATION FOR WHICH THE PRODUCT WAS NOT DESIGNED OR ANY OTHER MISUSE, NEGLIGENCE, INCORPORATION OR USE OF UNSUITABLE ATTACHMENTS OR PARTS, UNAUTHORIZED ALTERATION, IMPROPER INSTALLATION, OR ANY CAUSES OTHER THAN DEFECTS IN MATERIAL OR WORKMANSHIP OF THE PRODUCT.

TILLER TINES, ARE SPECIFICALLY NOT WARRANTED AGAINST DAMAGE, INCLUDING BUT NOT LIMITED TO, ABRASIVE DAMAGE.

Disclaimer of Consequential Damage and Limitation of Implied Warranties:

AMERICAN HONDA DISCLAIMS ANY RESPONSIBILITY FOR LOSS OF TIME OR USE OF THE PRODUCT, OR THE POWER EQUIPMENT ON WHICH THE PRODUCT IS INSTALLED, TRANSPORTATION, COMMERCIAL LOSS, OR ANY OTHER INCIDENTAL OR CONSEQUENTIAL DAMAGE. ANY IMPLIED WARRANTIES ARE LIMITED TO THE DURATION OF THIS WRITTEN WARRANTY. Some states do not allow limitations on how long an implied warranty lasts and/or do not allow the exclusion or limitation of incidental or consequential damages, so the above exclusions and limitations may not apply to you.

This warranty gives you specific legal rights, and you may also have other rights which vary from state to state.

EMISSION CONTROL SYSTEM WARRANTY

Your new Honda Power Equipment engine complies with the U.S. EPA, Environment Canada and State of California emission regulations. American Honda Motor Co., Inc. provides the emission warranty coverage for engines in the United States, and its territories. Honda Canada Inc. provides the emission warranty for engines in the 13 provinces and territories of Canada. In the remainder of this Emission Control System Warranty, American Honda Motor Company Inc. and Honda Canada Inc. will be referred to as Honda.

Your Warranty Rights And Obligations:

California

The California Air Resources Board and Honda are pleased to explain the emission control system warranty on your Honda Power Equipment engine. In California, new spark-ignited small off-road equipment engines must be designed, built and equipped to meet the State's stringent anti-smog standards.

Other States, U.S. territories and Canada

In other areas of the United States and in Canada, your engine must be designed, built, and equipped to meet the U.S. EPA and Environment Canada emission standards for spark-ignited engines at or below 19 kilowatts.

All of the United States and Canada

Honda must warrant the emission control system on your power equipment engine for the period of time listed below, provided there has been no abuse, neglect or improper maintenance of your power equipment engine. Where a warrantable condition exists, Honda will repair your power equipment engine at no cost to you including diagnosis, parts and labor.

Your emission control system may include such parts as the carburetor or fuel injection system, the ignition system, and catalytic converter. Also included may be hoses, connectors and other emission-related assemblies.

Manufacturer's Warranty Coverage:

The 1995 and later power equipment engines are warranted for two years. If any emission-related part on your engine is defective, the part will be repaired or replaced by Honda.

Owner's Warranty Responsibility:

As the power equipment engine owner, you are responsible for the performance of the required maintenance listed in your owner's manual. Honda recommends that you retain all receipts covering maintenance on your power equipment engine, but Honda cannot deny warranty coverage solely for the lack of receipts or for your failure to ensure the performance of all scheduled maintenance.

As the power equipment engine owner, you should however be aware Honda may deny you warranty coverage if your power equipment engine or a part has failed due to abuse, neglect, improper maintenance, or unapproved modifications.

You are responsible for presenting your power equipment engine to a Honda Power Equipment dealer as soon as a problem exists. The warranty repairs should be completed in a reasonable amount of time, not to exceed 30 days.

If you have any questions regarding your warranty rights and responsibilities, you should contact the Honda Office in your region:

American Honda Motor Co., Inc.
Power Equipment Customer Relations
4900 Marconi Drive
Alpharetta, Georgia 30005-8847
Telephone: (770) 497-6400

or

Honda Canada Inc.
Power Equipment Customer Relations
715 Milner Avenue
Toronto, ON M1B 2K8
Telephone: (888) 946-6329

TECHNICAL & CONSUMER INFORMATION

Warranty Coverage:

Honda power equipment engines manufactured after January 1, 1995 and sold in the State of California, U.S. EPA certified engines manufactured on or after September 1, 1996 and sold in all of the United States, and Canadian certified engines manufactured on or after January 1, 2005 are covered by this warranty for a period of two years from the date of delivery to the original retail purchaser. This warranty is transferable to each subsequent purchaser for the duration of the warranty period.

Warranty repairs will be made without charge for diagnosis, parts or labor. All defective parts replaced under this warranty become the property of Honda. Warranted parts are listed under *Emission Control System Warranty Parts* later on this page. Normal maintenance items, such as spark plugs and filters, that are on the warranted parts list are warranted up to their required replacement interval only.

Honda is also liable for damages to other engine components caused by a failure of any warranted part during the warranty period.

Only Honda approved replacement parts may be used in the performance of any warranty repairs and must be provided without charge to the owner. The use of replacement parts not equivalent to the original parts may impair the effectiveness of your engine emission control system. If such a replacement part is used in the repair or maintenance of your engine, and an authorized Honda dealer determines it is defective or causes a failure of a warranted part, your claim for repair of your engine may be denied. If the part in question is not related to the reason your engine requires repair, your claim will not be denied.

To Obtain Warranty Service:

You must take your Honda Power Equipment engine or the product on which it is installed, along with your sales registration card or other proof of original purchase date, at your expense, to any Honda Power Equipment dealer who is authorized by Honda to sell and service that Honda product during his normal business hours. Claims for repair or adjustment found to be caused solely by defects in material or workmanship will not be denied because the engine was not properly maintained and used.

If you are unable to obtain warranty service, or are dissatisfied with the warranty service you received, contact the owner of the dealership involved. Normally this should resolve your problem. However, if you require further assistance, write or call the Honda Power Equipment Customer Relations Department in your region.

Exclusions:

FAILURES OTHER THAN THOSE RESULTING FROM DEFECTS IN MATERIAL OR WORKMANSHIP ARE NOT COVERED BY THIS WARRANTY. THIS WARRANTY DOES NOT EXTEND TO EMISSION CONTROL SYSTEMS OR PARTS WHICH ARE AFFECTED OR DAMAGED BY OWNER ABUSE, NEGLIGENCE, IMPROPER MAINTENANCE, MISUSE, MISFUELING, IMPROPER STORAGE, ACCIDENT AND/OR COLLISION, THE INCORPORATION OF, OR ANY USE OF, ANY ADD-ON OR MODIFIED PARTS, UNSUITABLE ATTACHMENTS, OR THE UNAUTHORIZED ALTERATION OF ANY PART.

THIS WARRANTY DOES NOT COVER REPLACEMENT OF EXPENDABLE MAINTENANCE ITEMS MADE IN CONNECTION WITH REQUIRED MAINTENANCE SERVICES AFTER THE ITEM'S FIRST SCHEDULED REPLACEMENT AS LISTED IN THE MAINTENANCE SECTION OF THE PRODUCT OWNER'S MANUAL, SUCH AS: SPARK PLUGS AND FILTERS.

Disclaimer of Consequential Damage and Limitation of Implied Warranties:

AMERICAN HONDA MOTOR CO., INC. AND HONDA CANADA INC. DISCLAIM ANY RESPONSIBILITY FOR INCIDENTAL OR CONSEQUENTIAL DAMAGES SUCH AS LOSS OF TIME OR THE USE OF THE POWER EQUIPMENT, OR ANY COMMERCIAL LOSS DUE TO THE FAILURE OF THE EQUIPMENT; AND ANY IMPLIED WARRANTIES ARE LIMITED TO THE DURATION OF THIS WRITTEN WARRANTY. THIS WARRANTY IS APPLICABLE ONLY WHERE THE CALIFORNIA, U.S. EPA OR ENVIRONMENT CANADA EMISSION CONTROL SYSTEM WARRANTY REGULATION IS IN EFFECT.

Emission Control System Warranty Parts:

SYSTEMS COVERED BY THIS WARRANTY:	PARTS DESCRIPTION:
Fuel Metering	Carburetor assembly, Fuel injection pump, Fuel injection nozzle, Fuel regulator, Intake manifold
Exhaust	Catalyst
Air Induction	Air filter housing, Air filter element*, Crankcase breather tube
Ignition	Flywheel magneto, Ignition pulse generator, Ignition coil assembly, Ignition control module, Spark plug cap, Spark plug*
Miscellaneous Parts	Tubing, fittings, seals, gaskets, and clamps associated with these listed systems.

* Covered up to the first required replacement only. See the Maintenance Schedule on page 17.

INDEX

A	
Air Filter	
Cleaning	20
Inspection	19
Assembly	27
Attachments	5
B	
Before Operation	10
C	
Carburetor Adjustment	23
Carrying Handle	9
Choke Lever	8
Clothing Recommendations	10
Component Identification	7
Cooling Fin Inspection	23
D	
Damage Prevention Message Definition	1
Description of Controls	8
Drag Bar	9
E	
Emission Control System	35
Employer message	5
Engine	
Fuel Recommendations	24
Oil Change	18
Oil Level	18
Oil Recommendations	19
Operating Problems	32
Refueling	24
Serial Number	33
Switch	8,13
F	
Frame Serial Number	33
Fuel	
Additive to Extend Storage Life	29
Draining	25
Gasoline Recommendations	24
Refueling	24
Fuel Filter	25
G	
Gasoline Recommendations	24
H	
Handlebars	
Folding for Transportation	31
I	
Idle Speed Adjustment	23
Importance of Proper Assembly	27
Important Safety Precautions	27
Inspection Before Tilling	
Tiller	11
Tilling Area	11
M	
Maintenance	
Air Filter	19
Cooling Fins	23
Engine Oil	18
Fuel System	24
Idle Speed	17
Importance	16
Schedule	17
Spark Arrester	22
Spark Plug	21
Throttle Cable	23
Transmission	26
Modifications	5
Moving The Tiller	12
O	
Oil, Engine	
Change	18
Level Check	18
Recommendations	19
Operating the Tiller	14
Options	38
Oxygenated Fuels	34
P	
Parent's message	5
Parts, Replacement	35
Priming Bulb	8,13
Publications	38
R	
Recoil Starter	9,13
Replacement Parts	35

INDEX

S

Safety

Attachments and Modifications	5
Important Message to Employers	5
Important Message to Parents	5
Important Safety Information	4
Safety Label Locations	6
Safety Precautions	12
Serial Numbers	33
Spark Arrester Service	22
Spark Plug Service	21
Starting Problems	32
Starting/Stopping the Engine	13
Storage	29

T

Taking Care of Unexpected Problems	32
Throttle Lever	
Cable Inspection	23
Operation	8,14
Transmission	26
Transport Wheels	9,12
Transporting	31

U

Unpacking	28
---------------------	----

W

Warranty

Accessories, Replacement Parts, and Apparel	40
Distributors Limited	39
Emission Control System	41

QUICK REFERENCE

Fuel	Type	Unleaded gasoline with a pump octane rating of 86 or higher	See page 24.
	Capacity	0.58 US qt (.55 ℓ)	
Engine oil	Type	SAE 10W-30, API SJ or higher	See page 19.
	Capacity	2.7 fl oz (80 cc)	See page 18.
Transmission lubricant	Type	Grease (NLGI #2)	See page 26.
Spark plug	Regular	NGK CM5H	See page 21.
	Resistor*	NGK CMR5H	
Maximum engine speed		10,000 ± 200 rpm	See shop manual.
Throttle cable		Adjust for proper free play	See page 23.

* Resistor plugs reduce the interference with radio and television reception.

HONDA

The Power of Dreams

31V25002
00X31-V25-0020



Printed on
Recycled Paper

EM3 POM53749-A
IPC 23000.2005.05
PRINTED IN U.S.A.